

(3 Hours)

[Total Marks:80]

N. B.: 1) Question No. 1 is compulsory.

2) Attempt any three questions out of the remaining five questions.

3) Assume suitable data wherever necessary.

1. Answer the following (any four): 20
 - a) Explain granular noise and slope overload error in delta modulation.
 - b) Explain image frequency and double spotting in AM receivers.
 - c) Compare wideband and narrowband FM.
 - d) Determine the second, third and fifth harmonics for a 2kHz repetitive wave. Also find out the total harmonic distortion if the fundamental frequency amplitude is $10V_{rms}$, a second harmonic amplitude is $0.2 V_{rms}$, and a third harmonic amplitude is $0.1 V_{rms}$.
 - e) A certain transmitter radiates 9kW with the carrier unmodulated, and 10.125kW when the carrier is sinusoidally modulated. Calculate the modulation index. If another sine wave, corresponding to 40% modulation, is transmitted simultaneously, determine the total power radiated.

2.
 - a) With the help of a neat block diagram explain the third method for SSB generation. 5
 - b) For an AM signal $v(t)=500(1+0.4\sin(3140t))\sin(6.28\times 10^3t)$ volt find the upper sideband frequency, lower sideband frequency, bandwidth, and modulation index. Draw the frequency spectrum for the AM wave. 5
 - c) With a neat block diagram explain the working of superheterodyne receiver. State its merits and demerits. 10

3.
 - a) Explain noise triangle in FM. Hence explain pre-emphasis and de-emphasis. 10
 - b) Explain the Armstrong method of FM generation giving proper block diagram and vector diagram. 10

4.
 - a) Explain PAM, PWM and PPM generation with waveforms. 10
 - b) Explain frequency division multiplexing with a neat block diagram. 10

5.
 - a) Explain companding and state the laws for companding in PCM. 5
 - b) Explain negative peak clipping and diagonal clipping in diode detectors. 5
 - c) Explain Continuously Variable Slope Delta Modulation giving proper block diagram. 10

6.
 - a) Explain natural sampling and flat top sampling. What is aliasing error? 10
 - b) A 25MHz carrier is modulated by a 400Hz audio sine wave. If the carrier voltage is 4V and the maximum deviation is 10kHz, find the modulation index for FM and PM. If the modulating frequency is changed to 2kHz, calculate the new modulation index for FM and PM. 5
 - c) Calculate the image rejection of a receiver having an RF amplifier and an IF of 450kHz, if the Q_s of the relevant coils are 65, at an incoming frequency of i)1200 kHz and ii) 20MHz. Comment on the image frequency rejection at both frequencies. 5

(3 Hours)

[Total Marks: 80]

- Note: 1) Question no 1 is compulsory.
 2) Attempt any 3 question out of remaining.
 3) Each question carries 20 Marks.
 4) Figures to right indicate full marks.

- Q.1 a) Compute the Spearman's Rank correlation coefficient for the following data: [5]
 x : 18 20 34 52 12
 y : 39 23 35 18 46
- b) Evaluate $\int_0^{2+i} z^2 dz$ along the line $x=2y$. [5]
- c) Find the projection of $u = (3, 1, 3)$ along and perpendicular to $v = (4, -2, 2)$ [5]
- d) Find the eigen values of $5A^2 - 6A + I$ where $A = \begin{bmatrix} -1 & 5 & 9 \\ 0 & -3 & 4 \\ 0 & 0 & 2 \end{bmatrix}$ [5]
- Q.2 a) Find the extremals of $\int_{x_1}^{x_2} \frac{y'^2}{x^2} dx$ [6]
- b) Use Gram-Schmidt process to construct the orthogonal basis from $x_1 = (1, 1, 1)$, $x_2 = (0, 1, 1)$, $x_3 = (0, 0, 1)$. [6]
- c) Show that $A = \begin{bmatrix} 2 & 2 & 1 \\ 1 & 3 & 1 \\ 1 & 2 & 2 \end{bmatrix}$ is diagonalisable and hence find the transforming matrix and diagonal form of A. [8]
- Q.3 a) For a normal variable x , with mean 2.5 and standard deviation 3.5, find the probability that (i) $2 \leq x \leq 4.5$ and (ii) $-1.5 \leq x \leq 5.5$ [6]
- b) The ratio of the probability of 3 successes in 5 independent trials to the probability of 2 successes in 5 independent trials is 1:4. What is the probability of 4 successes in 6 independent trials? [6]
- c) Using Rayleigh-Ritz Method find the solution of $I = \int_0^1 (2xy + y^2 - y'^2) dx$ where $0 \leq x \leq 1$ and $y(0)=y(1)=0$. [8]
- Q.4 a) Find the line of regression of Y on X for following data [6]
 x : 10 12 13 16 17 20 25
 y : 19 22 24 27 29 33 37. Hence find the value of y at $x=15.5$
- b) Evaluate $\oint_C \frac{3z^2+2z-2}{(z-1)(z-2)} dz$ where C is the curve (i) $|z| = \frac{1}{2}$, (ii) $|z| = \frac{3}{2}$, (iii) $|z| = 3$ [6]
- c) Find the m.g.f. of Poisson's Distribution about origin. Hence find its mean and variance [8]
- Q.5 a) If x is a continuous random variable with probability distribution function [6]
 $f(x) = \begin{cases} \frac{x}{6} + k & \text{if } 0 \leq x \leq 3 \\ 0 & \text{otherwise} \end{cases}$ then find the value of k and $P(1 \leq x \leq 2)$
- b) If $A = \begin{bmatrix} 3 & 1 \\ 2 & 2 \\ 1 & 3 \\ 2 & 2 \end{bmatrix}$ then find the values of matrices e^A and 4^A . [6]
- c) Find all possible expansions of $f(z) = \frac{2-z^2}{z(1-z)(2-z)}$. [8]
- Q.6 a) Evaluate $\int_0^{2\pi} \frac{d\theta}{5+3\sin\theta}$ using Cauchy Residue Theorem. [6]
- b) Show that the matrix $A = \begin{bmatrix} 1 & 0 & 0 \\ 1 & -1 & 0 \\ 1 & 0 & -1 \end{bmatrix}$ is derogatory and find its minimal polynomial also. [6]
- c) Show that the set of real numbers is a vector space with the operations defined as $x + y = xy$ be addition and $cx = x^c$ be scalar multiplication. [8]

Time Duration: 3 hrs.

Max Marks: 80

Note

- Q.1 is compulsory
- Solve any 3 questions out of the remaining questions
- Figures to the right indicate full marks

Q.1 Solve any 4

- List the prominent features of super-scalar architecture. (5)
- State advantages of segmentation in 8086. (5)
- State the significance of queue in pipelining in 8086. (5)
- Explain the significance of following pins in 8086.
 - INTR
 - TEST*
 - DEN*
 - BHE/S7
 - ALE (* indicates bar) (5)
- Explain memory banking in 8086. (5)

- Q.2 a. Draw and explain minimum mode operation of 8086. (10)
- b. Draw and explain timing diagram for i) read ii) write cycle in 8086. (10)

- Q.3 a. Explain different addressing modes of 8086 with example. (10)
- b. Explain interrupt structure in 8086 (10)

- Q.4 a. Show interfacing of 8259 with 8086 in single mode and explain significant pins. (10)
- b. Write a program to blink port C bit 2 of 8255. Assume address of CWR of 8255 as 83H. Use bit Set/Reset mode. (5)
- c. Explain any 2 operating modes of DMA 8257. (5)

- Q.5 a. Draw and explain interfacing of 8086-8087 math-coprocessor. (10)
- b. Write a program in 8086 to exchange block of data consisting of 5 bytes at 1000H and 02000H using string instructions. (5)
- c. Explain following instructions in 8086. (5)
- LOOPE/ LOOPZ
 - JE/JZ
 - Call

- Q.6 Write short notes on any 4 (20)
- DOS interrupts.
 - Intel Pentium processor – Branch Prediction Logic
 - Mode 1 operation of 8255PPI
 - ICW's and OCW's in 8259
 - Operation of DMA controller

(3 Hours)

[Total Marks : 80]

Please check whether you have got the right question paper.

- N.B.:**
- 1) Question No.1 is compulsory.
 - 2) Attempt any three questions from remaining.
 - 3) All questions carry equal marks.
 - 4) Assume suitable data wherever necessary.

Q.1 Attempt **any four (04)** of the following:

20

- (a) Explain high frequency equivalent circuit of bipolar junction transistor (BJT).
- (b) Write short note on the Cascode amplifier configuration.
- (c) What are the advantages & disadvantages of negative feedback ?
- (d) State & explain the Barkhausen's criterion.
- (e) Describe what is cross-over distortion with a neat sketch.
- (f) With neat sketch describe the V-I characteristics of DIAC.

Q.2 (a) Determine the lower & upper cut-off frequency (f_L & f_H) for the single stage common collector (CC) BJT amplifier as shown in Fig. 1 below.

10

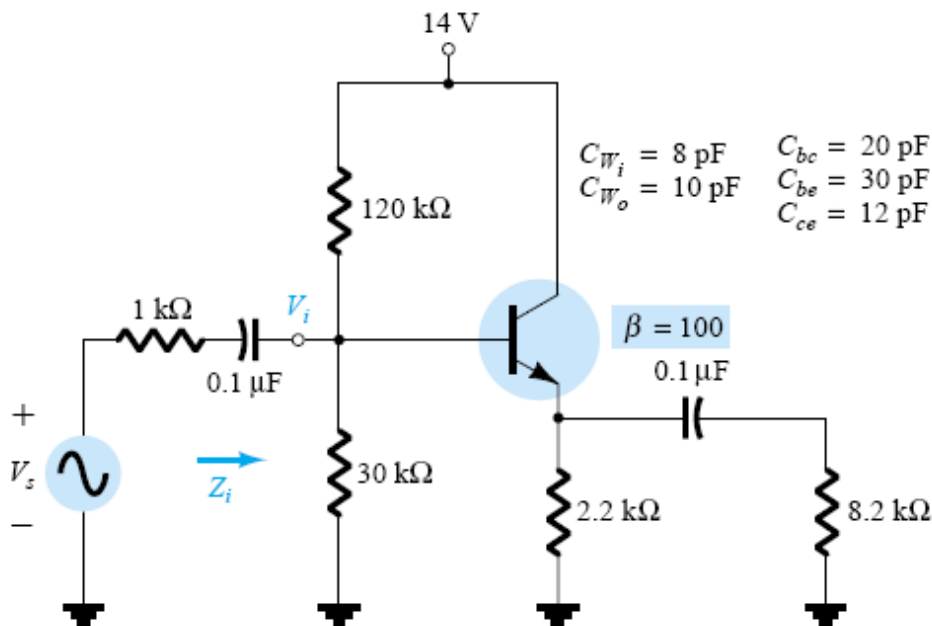

Fig. 1 – Common Collector (CC) BJT Amplifier for Q.2 (a)

Q.2 (b) Explain the high frequency response of CS – JFET amplifier with proper equations. Discuss the effects of various parasitic (inter-electrode & wiring) capacitances.

10

Q.3 (a) Draw Class A transformer coupled amplifier & load line, derive the expressions for the maximum overall operating efficiency $\eta_{o(max)}$ & maximum collector conversion efficiency $\eta_{c(max)}$.

10

Q.3 (b) Explain Class B push-pull amplifier with neat labeled diagram & derive the expressions for the maximum overall operating efficiency $\eta_{o(max)}$ & maximum collector conversion efficiency $\eta_{c(max)}$.

10

Q.4 (a) For the E – MOSFET differential amplifier as shown in the Fig. 2:-

10

- (i) Determine the DC operating point (Q – Point)
- (ii) Derive & calculate the differential mode gain (A_d)
- (iii) Derive & calculate the common mode gain (A_c)
- (iv) Calculate the common mode rejection ratio (CMRR)

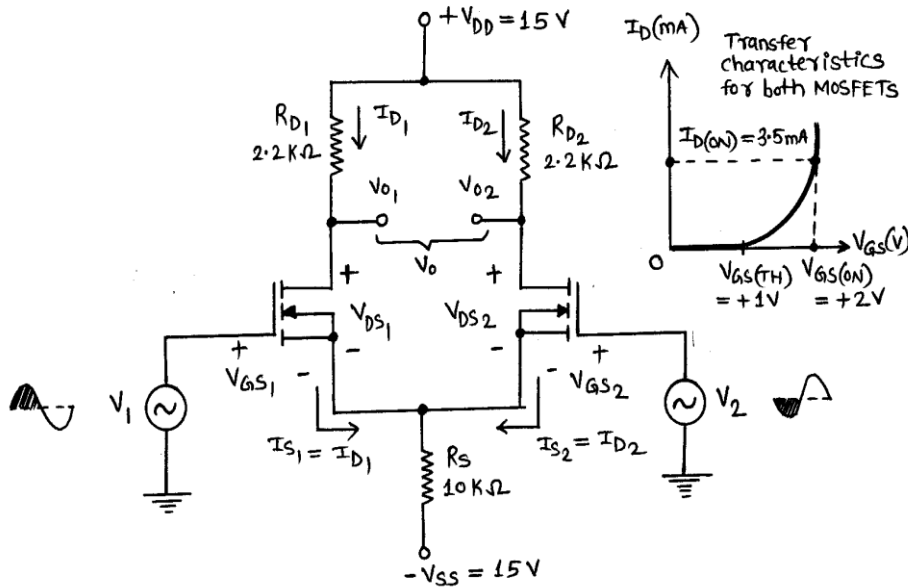

Fig. 2 – The E – MOSFET Differential Amplifier for Q.4 (a)

Q.4 (b) Identify the negative feedback topology as shown in the Fig. 3 below. Analyze to derive the expressions for the input resistance with feedback (R_{if}) & output resistance with feedback (R_{of}).

10

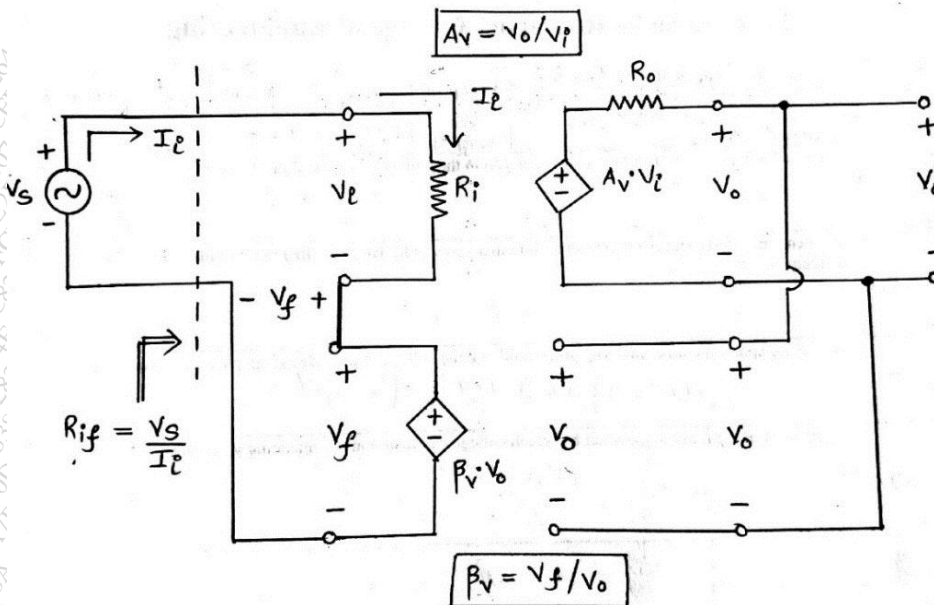

Fig. 3 – Negative Feedback Amplifier Topology for Q.4 (b)

Q.5 (a) With a neat labelled diagram, explain the Hartley oscillator. Describe its advantages & disadvantages. Design the same for 50 kHz. 10

Q.5 (b) Identify the low frequency RC oscillator from the Fig. 4 & explain its working with its advantages & disadvantages. From the given component values, calculate output frequency of oscillations (f_o). 10

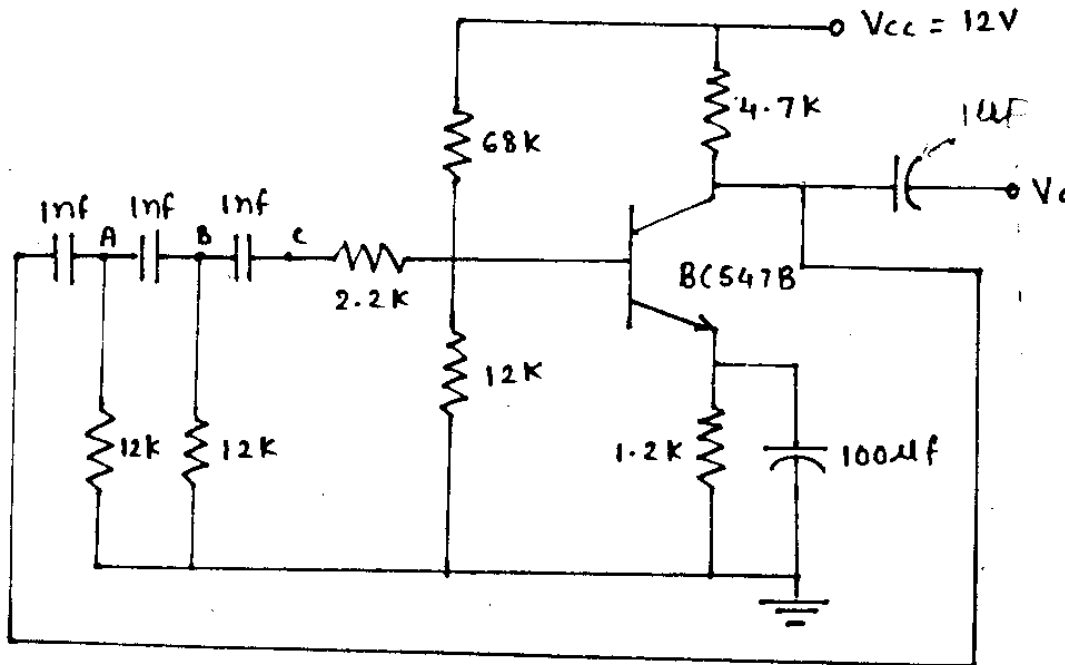

Fig. 4 – The low frequency RC oscillator for Q.5 (b)

Q.6 (a) Explain the working of silicon controlled rectifier (SCR) using the two-transistor analogy with a neat labelled diagram. Draw the structure / construction & V-I characteristics of SCR. 10

Q.6 (b) Describe construction & explain the working of uni-junction transistor (UJT) with neat labelled diagram & V-I characteristics. Define the term ‘intrinsic stand-off ratio’. 10

Time: 3 Hours

Marks: 80

1. Attempt Any Four Questions
2. Question No. 1 is Compulsory
3. Marks to the right indicate full marks
4. Assume suitable data wherever necessary.

Q1. Solve Any Four

10

- a) Draw block diagram and obtain transfer function of a simple closed loop system, with a forward path gain as $G(s)$ and feedback path gain as $H(s)$
- b) In complex “s” plane show pole locations for under damped, critically damped and over damped control systems.
- c) What are the effects of feedback on a system?
- d) Explain Importance of mathematical modeling.
- e) What is state transition matrix? State the properties of state transition matrix.

- 2a) Determine the transfer function C/R of a control system shown by following block diagram **10**

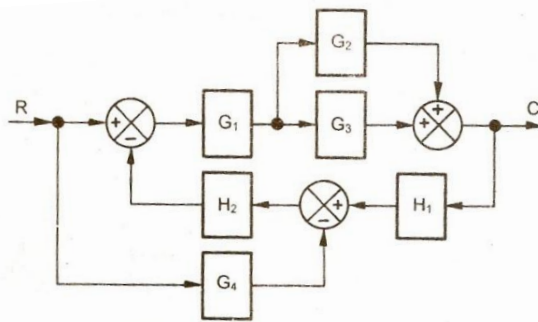

- 2b) Draw a Signal flow graph of the system in 2 a) and Obtain overall transfer function using Mason's Gain Formula **10**
- 3a) Define Controllability and Observability. Check the Controllability and Observability of the following State Space Model. **10**

$$\dot{x} = \begin{bmatrix} 2 & 1 \\ 1 & -2 \end{bmatrix} x + \begin{bmatrix} 1 \\ 1 \end{bmatrix} u;$$

$$y = [0 \quad 1]x$$

- 3b) For the given state variable model, obtain transfer function. **10**

$$\dot{x} = \begin{bmatrix} 0 & 1 \\ -2 & -3 \end{bmatrix} x + \begin{bmatrix} 1 \\ 0 \end{bmatrix} u:$$

$$y = [1 \quad 0]x$$

- 4a) Sketch Bode plot for a system whose open loop transfer function is **10**

$$G(s) = \frac{0.354 (s + 1)(1 + 0.05s)}{s(1 + 0.025s)}$$

- 4b) Sketch root locus for a unity feedback system, whose open loop transfer function is given as **10**

$$G(s) = \frac{K}{s(s + 2)(s + 4)}$$

- 5a) The open loop transfer function of a unity feedback system is given as **10**

$$G(s) = \frac{K}{s(s^2 + 4s + 13)}$$

Find the range of K for stability using Routh's stability criterion.

- 5b) Write the expression for a unit step response for a general second order system. Hence derive the expression for time to peak overshoot. **10**

- 6a) A unity feedback system has open loop transfer function as **10**

$$G(s) = \frac{40(s + 2)}{s(s + 1)(s + 4)},$$

Determine i) Type of a system, ii) Static error coefficients and iii) steady state error for ramp input with magnitude of 4.

- 6b) Write short note on any one of the following: **10**

- (i) Advances in Control Systems.
(ii) PID Controller

(3 Hours)

[Total Marks: 80]

- N.B: 1) Question no. 1 is compulsory.
 2) Attempt any three out of the remaining five questions
 3) Use suitable data, wherever necessary.

Question 1 : Attempt **any four** questions from the following.

20

- i. Explain Inspection Method of State Reduction.
- ii. Draw the Standard symbols for ASM Charts.
- iii. Write short note on VHDL Features.
- iv. Compose VHDL code for Half Adder using Behavioural Modelling Style.
- v. Design & Explain a MOD-10 counter with counting sequence 0,1,2,...9,1,2,3,...using IC 74x163

Question 2: Analyse the sequential state machine shown below. Obtain the excitation equation, transition table and state diagram for the same.

10

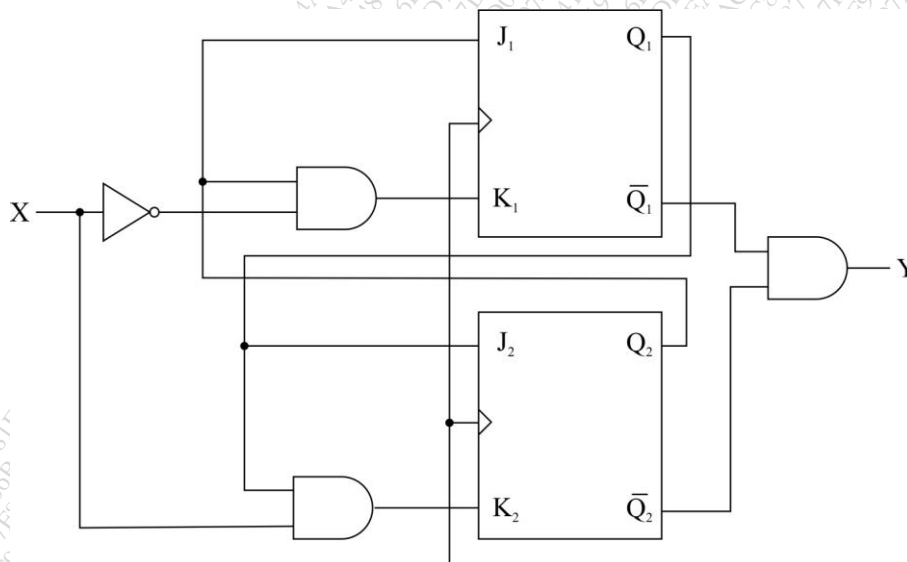

Question 2 b) With diagrams explain the meaning of following RTL statements (Assume all registers are 2-bit)

10

1. $Y \leftarrow X$
2. $C \leftarrow A \vee B$
3. $(\overline{X[1]}, X[1]/(5,7))$.

Question 3 a) Reduce the state of the following state table using Partition Method.

10

Present State (PS)	Next State (NS), Output (Z)	
	X=0	X=1
A	C,0	F,0
B	D,1	F,0
C	E,0	B,0

D	B,1	E,0
E	D,0	B,0
F	D,1	B,0

Question 3 b) Draw the Standard symbols for ASM Charts and convert the following state diagram to ASM Chart. 10

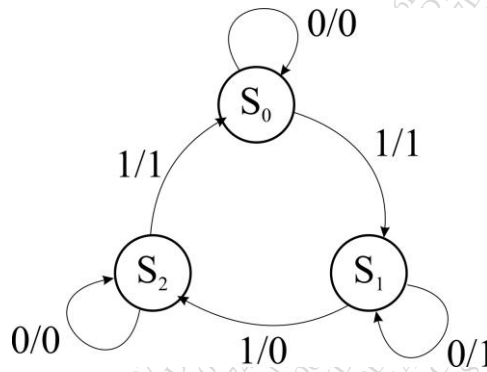

Question 4 a) Draw block diagram of 8:3 Octal to Binary Encoder and Compose VHDL code for same using behavioural modelling style. 10

Question 4 b) Design following using IC 7490: 10

1. MOD 97 Counter
2. MOD 45 Counter

Question 5 a) Discuss CPLD Xilinx XC 9500 architecture with neat block diagram. Describe main features. 10

Question 5 b) Design Full Adder using PLA. 10

Question 6 a) Explain in detail Structure of VHDL Module and also explain port modes in VHDL. 10

Question 6 b) Explain the application of shift register. 10