

(3 hours)

[Total Marks: 80]

Note:

1. Question-1 is compulsory.
2. Answer any three questions from remaining five.
3. Assume suitable data if necessary.
4. Numbers in the right indicate marks.

1. Answer the following questions. (Each question carry 5 marks) 20
 - (a) Distinguish between linear valve and equal percentage valve.
 - (b) Draw circuit diagram of a basic RC band-pass filter. Sketch its frequency response clearly showing the expressions for cut-off frequencies.
 - (c) Describe any two discontinuous controller modes.
 - (d) What are two PLC operation modes? Describe both modes in brief.
2. (a) Draw basic pneumatic system and describe its components. 10
 (b) Illustrate the working of V-to-I and I-to-V converters with neat circuit diagrams. 10
3. (a) Consider the instrumentation amplifier shown in figure below. Derive the expression for V_{out} and compute the resistors for the gain of 101. 10

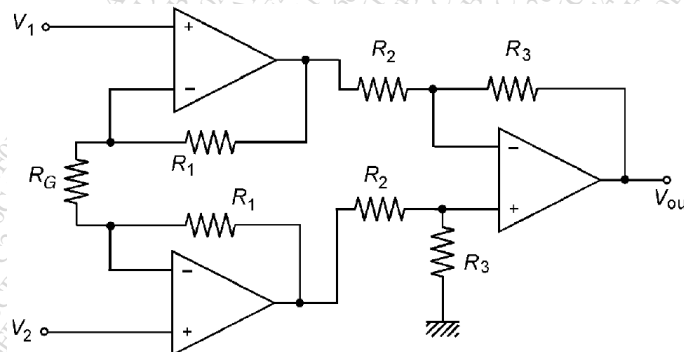

- (b) What are the criteria for selecting controller mode for a given process? Describe the ratio controller with clearly specifying the types of processes for which it is used. 10
4. (a) An integral controller is used for speed control with a setpoint of 12 rpm within a range of 10 to 15 rpm. The controller output is 22% initially. The integral gain $K_I = -0.15\%$ controller output per second per percentage error. If the speed jumps to 13.5 rpm, calculate the controller output after 2s for a constant e_p . 10
 (b) Draw the basic structure of PLC and describe its components in detail. 10

[TURN OVER]

- 5. (a) Develop the physical ladder diagram for a motor with the following: NO start button, NC stop button, thermal overload limit switch opens on high temperature, green light turns on when running, red light turns on for thermal overload. 10
 - (b) What is a Data Acquisition System (DAS)? Describe, with clear diagram, working of a typical DAS. 10

 - 6. Answer any two of the following questions. 20
 - (a) Write a short note on SCADA.
 - (b) What is the scope of standard NEMA 250? Describe its features in brief.
 - (c) List any five SAMA symbols. Draw clear symbol with brief description.
-

Time: - 3 Hours

Total Marks:- 80

Note: 1] Question No.1 is COMPULSORY.

2]Solve Any THREE questions from remaining.

2] All Questions carry equal marks.

Q1. [a] How are robot classified? [04]

[b] Define Precision, Accuracy, repeatability, DOF [04]

[c] Given $[p]^M=[0.6,0.5,1.4]^T$. Compute $[p]^E$ if [04]

$$A = \begin{bmatrix} 0 & -1 & 0 \\ 1 & 0 & 0 \\ 0 & 0 & 1 \end{bmatrix}$$

[d] Define kinematics parameters. What is soft home configuration? [04]

[e] State and Explain Single Axis Robot. [04]

Q 2. [a] What are Composite Rotation Matrices? How are they represented? [10]

[b] A robot joint has to move from an initial angle of $\theta_0=30^\circ$ to the final value of $\theta_f=150^\circ$ in 5 seconds. Find the cubic polynomial to generate smooth trajectory for the joint. Assume zero velocity at the starting and ending of the path. What is maximum velocity and acceleration for this trajectory? [10]

Q.3. [a] Explain Denavit-Hartenberg (D-H) Algorithm in detail [10]

[b] Derive Direct Kinematics of 3-Link manipulator shown below. [10]

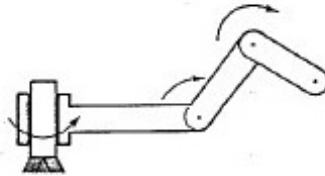

joint	θ	d	a	α
1	Θ_1	0	A1	-90
2	Θ_2	0	A2	0
3	Θ_3	0	A3	0

Q.4 [a] Obtain Tool Configuration Jacobian Matrix for Four Axis SCARA robot [10]

[b] For the three axis planar articulated robot shown in the figure, Find the joint variables q when the first two links form a right angled triangle, given TCV as $W(q) = \{a_2, a_1, d_3, 0, 0, 1\}^T$. [10]

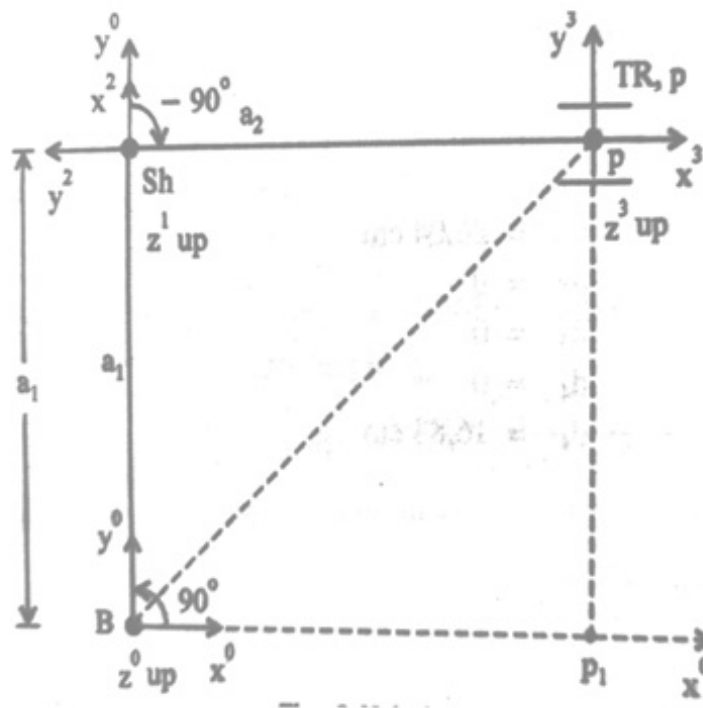

5 [a] Explain the edge detection algorithm. [10]

[b] What are the template matching techniques ? Explain Normalized Cross Correlation in detail for an image

2	1	0	0	3
0	0	5	0	0
0	4	0	6	0
1	0	5	0	0

For a mask/template

0	4	0
3	0	5
0	4	0

[10]

Q.6. [a] Explain any one of the technique in path planning algorithms . [10]

[b] Explain Shrink operators, their usage and comment on convergence for the image given below 10]

0	0	0	0	0	0
1	1	1	1	1	0
0	0	1	1	1	0
0	0	1	1	1	0
0	0	0	0	0	0

(3 Hours)

[Total Marks: 80]

NOTE:-1) Question 1 is compulsory

- 2) Solve **any three** from the remaining five questions
- 3) Assume suitable data if necessary.
- 4) Figures to the right indicate full marks

- Q.1. a.** What is the need of multirate processing? Give some examples of multirate digital systems. **20**
- b.** What is Digital Signal Processor and explain it's basic characteristics.
- c.** What is the relation between digital and analog frequency in impulse invariant transformation .What is aliasing ?
- d.** What do you mean by overflow limit cycles ? How it can be avoided?
- Q.2. a.** Design a high pass filter using Hamming window with cut off frequency of 1.2 rad/sec and number of coefficients =9. **10**
- b.** Explain Gibb's phenomenon in FIR filter design. **10**
- Q.3. a.** Explain frequency warping effect in BLT in detail. **10**
- b.** The digital filter with system function $H(z) = \frac{0.5Z}{z-0.5}$ Find the output noise power from digital filter when input is quantized to have 8- bits. **10**
- Q.4. a.** Explain the application of DSP in speech. **10**
- b.** Explain how higher throughput is obtained in DSP using the VLIW architecture. **10**
- Q.5. a.** Find DFT of $x(n)=2^n$ using the 8-point DIT-FFT algorithm. **10**
- b.** Develop a radix -2 DIF -FFT algorithm for computing 8 point DFT. **10**
- Q.6. a.** Explain in detail polyphase decomposition. **10**
- b.** What is the need for multistage filter implementation. Explain it's drawbacks. **10**

(3 Hours)

[Total Marks: 80]

- N.B.:** 1. **Question No. 1 is compulsory.**
2. Answer **any three** from remaining questions.
3. **All questions carry equal marks.**

Q. 1 Answer any four:

20

- What is need for Wireless Sensor Network (WSN)? Mention applications.
- How cell switching is done in Asynchronous Transfer Mode (ATM).
- Explain the steps for completing access layer design.
- What is IEEE 802.15.3a Ultra Wide Band (UWB)?
- Differentiate between unicast routing and multicast routing protocols.

Q.2 (a) With a neat diagram explain Bluetooth protocol stack with neat diagram.

10

(b) Explain network security threats and safeguards in detail.

10

Q. 3 (a) What is Remote Monitoring (RMON)? Explain the benefits of RMON.

10

(b) Bring out the advantages of optical networking with a neat diagram, explain SONET hardware components.

10

Q.4 (a) Enlist and explain various deployment models of cloud computing.
What are key drivers to adoption of cloud?

10

(b) Draw and explains Dense Wavelength Division Multiplexing (DWDM) architecture in detail.

10

Q.5 (a) Explain 802.11 Media Access Control (MAC) frame format.
Describe the services offered by MAC.

10

(b) Explain Open Shortest Path First (OSPF) protocol in detail.

10

Q.6 Write a short note on any four :

20

- Compare Infrastructure networks and Ad-hoc networks.
- Zigbee technology.
- Impact of cloud on users.
- Packet filtering.
- Radio Frequency Identification (RFID).

(3 Hours)

(Total Marks : 80)

- N.B:** 1) **Q.1** is compulsory.
2) Attempt **any THREE** questions from the remaining questions.
3) Assume suitable **data** if **necessary**.

Q.1 Attempt **any four** :

- a) Compare active attacks vs Passive attacks. [5]
- b) Explain various types of key-loggers in brief. [5]
- c) Classify the cybercrimes and explain any one briefly. [5]
- d) Explain how the appeals can be made under The IT ACT 2000. [5]
- e) Write brief note on : Cyber-terrorism. [5]

Q.2 a) How criminals plan the attack? Discuss various steps involved [10]

b) Explain how Intellectual property laws protect the rights of the owner of the intellectual Property. [10]

Q.3 a) Compare Vishing, Phishing and Smishing in cyber security. [10]

b) What is E-commerce? Explain different types of e-commerce with suitable examples. [10]

Q.4 a) What is Bluetooth hacking? Explain Bluetooth hacking tools in brief. [10]

b) How the Indian penal code IPC 1860 addresses cybercrime? [10]

Q.5 a) Discuss basic security precautions to be taken to safeguard Laptops and wireless devices. [10]

b) What is E-contract? Discuss E-contract Act 1872. [10]

Q.6 Write short note on (Any 2) : [20]

- 1) Computer Sabotage.
- 2) Indian Information Technology Act 2000
- 3) Write key IT requirements for SOX and HIPAA.

Time: 3 Hours

Total Marks: 80

NB: (1) Question No. 1 is compulsory.

(2) Attempt any three questions from remaining five questions.

(3) Assume suitable data if required but justify the same.

(4) Figures to the right indicate full marks

Q.1. Attempt any four from following

20

- Describe different modes of operation of SCR with the help its static V-I characteristics and explain what is holding current and latching current.
- Explain single phase full-bridge inverter with R load.
- Explain with the help of neat circuit diagram and waveforms what the effect of freewheeling diode is on the performance of single phase half wave controlled rectifier with RL load.
- What are turn on methods of SCR? What are the basic requirements for successful turn on of SCR? Which is the best method of SCR triggering explain why?
- Describe the principle of on-off control and phase control.

Q.2. a Draw ramp and pedestal trigger circuit used for single phase semi converter. Describe its operation with appropriate waveforms 10

- What are turning off methods of SCR. Explain the Class D commutation method with the help of neat circuit diagram and waveforms, also give the design concepts of class D commutation. 10

Q.3. a Discuss the effect of source inductance on the performance of single phase fully controlled converter, indicating clearly the conduction of various thyristors during one cycle. Derive an expression for its output voltage in terms of 10

(1) Maximum voltage E_m , Firing angle α and overlap angle μ .(2) E_m , α , L_s (source inductance) and I_d (load current).

- A single phase fully controlled bridge converter supplies an inductive load. Assuming that the output current is virtually constant and is equal to I_d , determine the following performance measures, if the supply voltage is equal to 230 V and if the firing angle is maintained at $(\pi/6)$ radians. 10

(i) Average output voltage (ii) Supply RMS current (iii) Supply fundamental RMS current (iv) Fundamental power factor (v) Supply power factor

(vi) Supply harmonic factor (vii) Voltage ripple factor

77334

Page 1 of 2

- Q.4. a Draw and explain the basic series inverter circuit employing class A type commutation. Draw and discuss the important waveforms. State the limitations of this series inverter. **10**
- b A single phase full bridge inverter is operated from a 48 V battery and is supplying power to a pure resistive load of 10Ω . Determine **10**
- (i) Fundamental output voltage and the first five harmonics.
 - (ii) RMS value by direct integration method and harmonic summation method.
 - (iii) Output RMS power and output fundamental power.
 - (iv) Transistor switches ratings.
- Q.5. a Draw the schematic of step-up and step-down choppers and derive an expression for output voltage in terms of duty cycle for a step-up and step-down chopper. **10**
- b The input voltage to the boost DC-DC switch mode regulator is 6 V. The average output voltage is 18 V and the average load current is 0.4 A. The switching frequency is 20 KHZ of $L = 250 \mu\text{H}$ and $C = 420 \mu\text{F}$. Determine **10**
- i) The duty cycle α , ii) The ripple current of inductor, iii) The peak current of inductor, and iv) The ripple voltage of filter capacitor
- Q.6. Write a short note on **any three** of the following. **20**
- (i) Single phase cyclo-converter
 - (ii) Battery charging systems
 - (iii) Static characteristics of IGBT
 - (iv) Protection of SCR against dv/dt , di/dt , over current and over voltage.

3 Hours

Total: 80 marks

- N.B:** (1) Question no 1 is compulsory
 (2) Attempt any **three** out of remaining **five** questions
 (3) Figures to the right indicate full marks
 (4) Assume Suitable data if necessary
 (5) Notations carry usual meaning

Q.1 Answer **any four** of the following questions:

a) Write the dual of the following LPP

Maximise $Z = 4x_1 + 2x_2$

Subject to ,

$x_1 - 2x_2 \geq 2$

$x_1 + 2x_2 = 8$

$x_1 - x_2 \leq 10$

Where $x_1 \geq 0, x_2$ is unrestricted in sign.

(05)

b) What are assumptions made in game theory

(05)

c) Write short note on special cases in Linear Programming Problem.

(05)

d) Enlist assumptions in sequencing problem.

(05)

e) Briefly explain Monte Carlo simulation with suitable example.

(05)

Q.2 a) Solve by Simplex Method:

Maximize $Z = 3x_1 + 2x_2$

Subject to

$x_1 + x_2 \leq 4,$

$x_1 - x_2 \leq 2$

Where $x_1, x_2 \geq 0$

(10)

b) Workers come to tool store room to receive special tools (required by them) for accomplishing a particular project assigned to them. The average time between two arrivals is 60 seconds and the arrivals are assumed to be in Poisson distribution. The average service time (of tool room attendant) is 40 seconds. Determine

- 1) Average queue length
- 2) Average length of non empty queue
- 3) Average number of workers in system
- 4) Mean waiting time of an arrival
- 5) Average waiting time of an arrival (worker) who waits.

(10)

Q.3 a) Solve the following by Vogel's Approximation Method (VAM) and find optimal transportation plan. (10)

	D₁	D₂	D₃	D₄	Supply
S₁	19	30	50	10	7
S₂	70	30	40	60	9
S₃	40	8	70	20	18
Demand	5	8	7	14	

b) Iyengar Bakery keeps stock of a popular brand of cake. Previous experience indicates the daily demand as given here: **(10)**

Daily Demand	0	10	20	30	40	50
Probability	0.01	0.20	0.15	0.50	0.12	0.02

Consider the following sequence of random numbers:
48,78,19,51,56,77,15,14,68,09

Using this sequence simulate the demand for the next 10 days. Find out the stock situation if the owner of the bakery decided to make 30 cakes every day. Also estimate the daily average demand for this cake on the basis of simulated data.

Q.4 a) Solve the following Assignment Problem. **(10)**

Contractors	Cost of Repairs (Rs.in Lakhs) of Roads			
	R₁	R₂	R₃	R₄
C₁	9	14	19	15
C₂	9	17	20	19
C₃	9	18	21	18
C₄	10	12	18	19
C₅	10	15	21	16

Rs.50 Lakhs is total cost of repair.

- 1) Find the best way of assigning the repair work to the contractors and cost.
- 2) If it is necessary to seek supplementary grants, then what should be the amount?
- 3) Which of the 5 contractors will be unsuccessful in his bid?

b) A distance network consists of eleven nodes which are distributed as shown in following table. Find the shortest path from node 1 to node 11 using dynamic programming. The corresponding distance are: **(10)**

Arc	Distance	Arc	Distance
1-2	8	5-8	12
1-3	7	5-9	7
1-4	1	6-9	9
2-5	5	7-9	6
3-5	9	7-10	13
3-6	2	8-11	4
3-7	8	9-11	2
4-7	10	10-11	15

Q.5 a) A and B play a game in which each has three coins a 5p, a 10p and 20p. Each player selects a coin without the knowledge of the others choice. If the sum of the coin is an odd amount, A wins B's coin; if the sum is even, B wins A's coin. Find the best strategy for each player and the value of the game. **(10)**

b) Solve by **Big-M or Charne's Penalty Method** **(10)**

Maximize $Z = 4x_1 + x_2$
 Subject to $3x_1 + x_2 = 3$
 $4x_1 + 3x_2 \geq 6$
 $x_1 + 2x_2 \leq 4$
 Where $x_1, x_2 \geq 0$

Q.6 a) A book binder has one printing press, one binding machine and the manuscript of number of different books. The time required to perform the printing and binding operation for each book are given below. Determine the order in which book should be processed, in order to minimise the total time required to turn out all the books. Also find the idle time of binding machine. **(10)**

Books	1	2	3	4	5	6
Printing time (hr)	30	120	50	20	90	110
Binding time (hr)	80	100	90	60	30	10

b) Mini Computer Company purchases a component of which it has a steady usage of 1000 units per year. The ordering cost is Rs.50 per order. The estimated cost of money invested is 25% per year. The unit cost of the component is Rs.40. Calculate the optimal ordering policy and total cost of inventory system, including purchase cost of the components. If the component supplier agrees to offer price discounts of minimum lot supplies as per schedule given below, reassess the decision on optimal ordering policy and total cost. **(10)**

Lot size	Price
Upto 149	Rs.40
150-499	Rs.39
500 or More	Rs.38

-----The End-----

Time: 3 Hours

Marks: 80

- N:B** (1) Question 1 is Compulsory.
(2) Attempt any three from the remaining questions.
(3) Figures to the right indicate full marks.

- Q.1** Attempt any four **5*4=20M**
- A** What is information system? Explain the necessary element with neat diagram
 - B** Define Big Data and discuss its basic characteristics?
 - C** Explain the Ethical issues and threats of information security?
 - D** Describe how social computing inspires customer service
 - E** Differentiate between computer network wired and wireless technology
- Q.2 A** List the types of Information system? Explain in brief **10M**
- B** Discuss competitive advantage achieved in Information System **10M**
- Q.3 A** Explain the architecture of Data mart and Data warehouse in an organization **10M**
- B** Discuss the Impact of BI on Decision Making. **10M**
- Q.4 A** What are the potential benefit of social commerce to the customers and to the business? **10M**
- B** What are major security threats to the information system? Discuss the measures taken to control information security. **10M**
- Q.5 A** Discuss the significance of social computing in marketing in detail **10 M**
- B** What are the functional areas of Information system. Explain in detail **10 M**
- Q.6 A** Define CRM. Describe the different types of CRM **10M**
- B** Design MIS for the Educational System **10M**
