

Q. P. Code : 545800

Duration: 3 Hours

(Revised Course)

Total Marks: 80

N.B. : 1) Q.1. is compulsory.

2) Attempt any three from the remaining.

Q.1. a) If  $f(x)$  is an algebraic polynomial in  $x$  and  $\lambda$  is an eigen value and  $X$  is the corresponding eigen vector of a square matrix  $A$  then  $f(\lambda)$  is an eigen value and  $X$  is the corresponding eigenvector of  $f(A)$ . (5)

b) Find the extremal of  $\int_{x_0}^{x_1} (x + y')y' dx$  (5)

c) Express  $(6, 1, 1, 6)$  as linear combination of  $v_1 = (2, 1, 4), v_2 = (1, -1, 3), v_3 = (3, 2, 5)$ . (5)

d) Evaluate  $\int_C \frac{z}{(z-1)^2(z-2)} dz$ , where  $C$  is the circle  $|z-2|=0.5$  (5)

Q.2. a) Find the curve  $y = f(x)$  for which  $\int_0^{\pi} (y'^2 - y^2) dx$  is extremum if  $\int_0^{\pi} y dx = 1$ . (6)

b) Evaluate  $\int_0^{2\pi} \frac{\cos 3\theta}{5 + 4 \cos \theta} d\theta$  (6)

c) Find the singular value decomposition of  $\begin{bmatrix} 2 & 3 \\ 0 & 2 \end{bmatrix}$  (8)

Q.3. a) Verify Cayley Hamilton theorem for  $A = \begin{bmatrix} 3 & 10 & 5 \\ -2 & -3 & -4 \\ 3 & 5 & 7 \end{bmatrix}$  and hence, find the matrix represented by  $A^6 - 6A^5 + 9A^4 + 4A^3 - 12A^2 + 2A - I$ . (6)

b) Construct an orthonormal basis of  $R^3$  using Gram Schmidt process to  $S = \{(3, 0, 4), (-1, 0, 7), (2, 9, 11)\}$  (6)

c) Find all possible Laurent's expansions of  $\frac{z}{(z-1)(z-2)}$  about  $z = -2$  indicating the region of convergence. (8)

[Turnover]

Q.4. a) Reduce the quadratic form  $2x^2 - 2y^2 + 2z^2 - 2xy - 8yz + 6zx$  to canonical form and hence find its rank, index and signature and value class. (6)

b) If  $\phi(\alpha) = \int_C \frac{4z^2 + z + 5}{z - \alpha} dz$ , where C is the contour of the ellipse  $\frac{x^2}{4} + \frac{y^2}{9} = 1$ , find the values of  $\phi(3.5), \phi(i), \phi'(-1), \phi''(-i)$  (6)

c) Using Rayleigh-Ritz method, solve the boundary value problem  $I = \int_0^1 (y'^2 - y^2 - 2xy) dx$ ;  $0 \leq x \leq 1$ , given  $y(0) = y(1) = 0$ . (8)

Q.5. a) Find the extremal of the function  $\int_0^{\pi/2} (2xy + y^2 - y'^2) dx$ ; with  $y(0) = 0, y(\pi/2) = 0$  (6)

b) Find the orthogonal matrix P that diagonalises  $A = \begin{bmatrix} 4 & 2 & 2 \\ 2 & 4 & 2 \\ 2 & 2 & 4 \end{bmatrix}$  (6)

c) Using Cauchy's Residue theorem, evaluate  $\oint_C \frac{z^2 + 3}{z^2 - 1} dz$  where C is the circle (i)  $|z - 1| = 1$  (ii)  $|z + 1| = 1$ . (8)

Q.6. a) Find the sum of the residues at singular points of  $f(z) = \frac{z}{(z-1)^2(z^2-1)}$  (6)

b) If  $A = \begin{bmatrix} 1 & 4 \\ 2 & 3 \end{bmatrix}$ , prove that  $A^{50} - 5A^{49} = \begin{bmatrix} 4 & -4 \\ -2 & 2 \end{bmatrix}$  (6)

c) (i) Check whether  $W = \{(x, y, z) \mid y = x + z, x, y, z \text{ are in } \mathbb{R}\}$  is a subspace of  $\mathbb{R}^3$  with usual addition and usual multiplication. (4)

(ii) Find the unit vector in  $\mathbb{R}^3$  orthogonal to both  $u = (1, 0, 1)$  and  $v = (0, 1, 1)$ . (4)

Sem-IV  
ETRX (CBGS)

24/11/2016

Discrete Electronic Circuit QP Code : 547804

(3 Hours)

[ Total Marks : 80

- N.B. : (1) Question No. 1 is compulsory  
 (2) Solve any three from remaining questions.  
 (3) Assume suitable data if necessary.  
 (4) Draw neat and clean diagram

1. Solve any four.

(a) For the given circuit Draw output voltage waveform

5

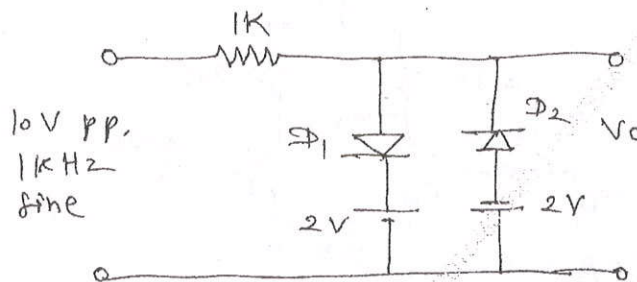

(b) Design fixed bias JFET circuit for  $I_D = 3\text{mA}$ .

5

Assume  $I_{DSS} = 10\text{mA}$  &  $V_p = -6\text{V}$

(c) Compare CS-CS Amplifier with CE-CE Amplifier

5

(d) What are disadvantages of colpitt oscillator

5

(e) Explain any one technique to improve CMRR in differential amplifier.

5

2. (a) For the given circuit find  $I_{CQ}$ ,  $V_{CEQ}$ ,  $V_C$  &  $V_E$ .

10

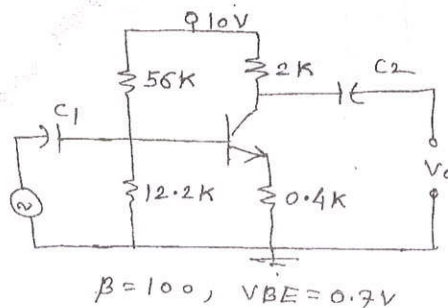

[TURN OVER]

2. (b) Derive equation of voltage gain, Input resistance and output resistance of voltage divider biased JFET amplifier. 10
3. (a) Explain High frequency response of JFET amplifier. 10  
 (b) Explain Wien bridge oscillator in brief. 10
4. (a) For the given differential amplifier, Calculate 10  
 (i) Q-point ( $I_{CQ}$  and  $V_{CEQ}$ )  
 (ii) Differential Gain ( $A_d$ )

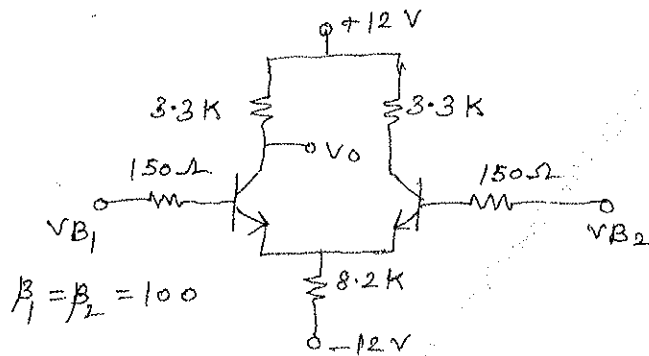

4. (b) For the given FET circuit find  $I_{DQ}$  and  $V_{DSQ}$  10

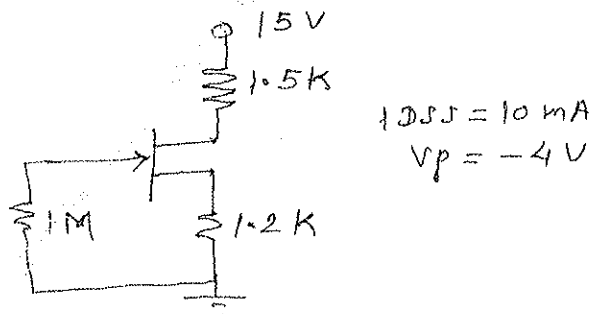

[TURN OVER]

QP Code : 547804

3

5. (a) Explain class B power Amplifier in brief. 10  
(b) Explain CASCODE Amplifier with its applications. 10
6. Write short note on : 20
- (a) Voltage shunt feedback Amplifier.
  - (b) Wilson Current Source
  - (c) Darlington Amplifier
  - (d) Difference between CB and CC Amplifier
-



**Q.P. Code : 548002**

**( 3 Hours)**

**[ Total Marks : 80**

- N.B. :** (1) Question No.1 is **compulsory**  
(2) Attempt any **three** questions out of remaining **five** questions.  
(3) Assume any suitable data wherever required and justify the same.

- Q1. Attempt the following. 20
- a) Compare architectural features of 8085 and 8086.
  - b) What is multiprocessor system? Give advantages.
  - c) Explain memory R/W cycle of any processor.
  - d) What is interrupt? Give its application
- Q2 a) Describe architecture of 8086. 10  
b) Explain 8237-DMAC and its interfacing. 10
- Q3 a) Explain various addressing modes of 8086 with examples. 10  
b) What is 8255-PPI? Draw interfacing of 8255 with 8085/86. 10
- Q4 a) Write an 8086 assembly language program for ordering (ascending or descending) a sequence of 5 numbers. 10  
b) What is need of bus arbitration? Explain 8289. 10
- Q5 Interface 64 K bytes of program memory (ROM) and 12 K bytes of data memory (RAM), 8bit I/O ports with 8086. Draw detailed circuit diagram, Memory map, I/O map. (Assume 8K capacity devices) 20
- Q6 Write short notes on. 20
- a) Loosely coupled system.
  - b) Segmentation in 8086: usages and challenges.
  - c) Nested interrupts using 8259PIC.
-





QP CODE : 548103

(3 Hours)

[Total Marks : 80

NB:-

- Question number 1 is compulsory.
- Attempt any three questions out of remaining questions.
- Assume suitable data wherever necessary.

1. Attempt following questions;

20

- Compare Open loop control system with closed loop control system.
- Explain the methods to determine the stability of system.
- How to find GM and PM from Bode plot.
- Explain Lag-Lead Compensation.

2. a) Explain and derive the rules for reduction of block diagram in control system.

10

b) Determine the transfer function of the control system represented by following block diagram

10

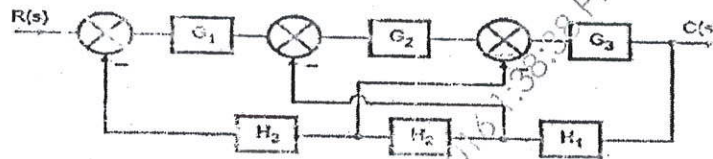

3. a) The open loop transfer function of a unity feedback system is given by

10

$$G(s) = \frac{K(s+1)}{s(s+2)(s+3)}$$

Sketch the root locus and find the range of values of K for the system to be stable

b) Explain the rules to construct the root locus.

10

4. a) Examine the observability of the system given below.

10

$$\begin{bmatrix} \dot{x}_1 \\ \dot{x}_2 \\ \dot{x}_3 \end{bmatrix} = \begin{bmatrix} 0 & 1 & 0 \\ 0 & 0 & 1 \\ 0 & -2 & -3 \end{bmatrix} \begin{bmatrix} x_1 \\ x_2 \\ x_3 \end{bmatrix} + \begin{bmatrix} 0 \\ 0 \\ 1 \end{bmatrix} u = Ax + Bu$$

b) Derive the time response expression for second order underdamped control system for unit step input.

10

TURN OVER

5. a) Sketch the Bode Plot for the open loop transfer function given by

10

$$G(s) = \frac{4(s+5)(s+10)}{s^2(s+20)}$$

- b) Explain the correlations between time and frequency domain specifications of the system.

10

6. a) Find polar plot for the transfer function given below

10

$$G(s) = \frac{12}{s(s+1)}$$

- b) A system is represented by the state equation

10

$$\dot{x}(t) = \begin{bmatrix} 0 & 1 \\ -4 & -5 \end{bmatrix} x(t) + \begin{bmatrix} 0 \\ 1 \end{bmatrix} u(t)$$

Find the State transition matrix.

MUPD16460 Sc60 12/15/2016 1:38:36 PM MUPD16460 Sc60 12/15/2016 1:38:36 PM MUPD16460 Sc60 12/15/2016 1:38:36 PM MUPD16460 Sc60 12/15/2016 1:38:36 PM

Course: S.E. (Sem IV) (CBSGS) (All Branch)

QP Code: 548103

---

Question No. 4 a

Please read it as follows:

$$\begin{bmatrix} \dot{x}_1 \\ \dot{x}_2 \\ \dot{x}_3 \end{bmatrix} = \begin{bmatrix} 0 & 1 & 0 \\ 0 & 0 & 1 \\ 0 & -2 & -3 \end{bmatrix} \begin{bmatrix} x_1 \\ x_2 \\ x_3 \end{bmatrix} + \begin{bmatrix} 0 \\ 0 \\ 1 \end{bmatrix} u = Ax + Bu$$

---

Query Update time: 15/12/2016 04:49 PM



SR Sem - IV  
ELTX (CBGS)  
F.C.E.

21/12/16

QP Code : 548203

( 3 Hours)

[ Total Marks : 80

- N.B. :** (1) Question No. 1 is **compulsory**.  
(2) Solve any **four** questions out of remaining **six**.  
(3) Assume suitable data if required.  
(4) Figures to the right indicate full marks.

1. Answer **any four** questions from the following :- 20
    - (a) Calculate the percentage power saving in AM modulated wave to a depth of 100 percent, when the carrier and one of the sidebands are suppressed.
    - (b) Describe briefly the forms of various noises.
    - (c) Explain natural and flat top sampling compare the two.
    - (d) Explain companding and its need in communication.
    - (e) What is ionosphere? How does it help in Electromagnetic wave propagation.
  
  2. (a) With the help of Block diagram explain superheterodyne Receiver. 10  
(b) The output voltage of a transmitter is given by  $500 ( 1 + 0.4 \sin 3140 t ) \sin 6.28 t$ . This voltage is fed to a load of  $600 \Omega$  resistance Determine 10
    - (i) Carrier frequency
    - (ii) Modulating frequency
    - (iii) Carrier power
    - (iv) Mean Power output
    - (v) Peak Power output
  
  3. (a) Describe delta modulation system. What are its limitations? How can be they overcome? 10  
(b) Explain Armstrong method of FM generation with the help of a neat block diagram and phasor diagram. 10
  
  4. (a) Explain the following terms as applied to wireless communication. 10
    - (i) Signal to -noise ratio
    - (ii) noise figure  
(b) Explain the operation of the balanced slope detector using a circuit diagram 10
  
  5. (a) Explain generation of PAM, PPM and PWM with waveforms. 10  
(b) State and explain important parameters of radio receiver. 10
  
  6. Write short notes on any **three** :- 20
    - (a) AGC
    - (b) FM noise triangle
    - (c) FDM and TDM
    - (d) Pre-emphasis and De-emphasis
-



Q.P. Code : 548301

(3 Hours)

[Total Marks : 60]

- N.B. :** (1) Question No. 1 is **compulsory**  
 (2) Figures to the right indicate **full marks**  
 (3) Solve any **three** questions out of remaining **five** questions  
 (4) Assume suitable data if necessary

1. Solve any **three**:-

15

- (a) A pole 3 phase, 50Hz induction motor runs at a speed of 1470 rpm speed. Find the frequency of the induced emf in the rotor under this condition.  
 (b) State and explain voltage equations of a dc motor.  
 (c) Define the slip of an induction motor explain its significance.  
 (d) Explain the construction of permanent magnet synchronous motor.  
 (e) Susitched reluctance motor.

2. (a) Derive the torque equation for a three-phase induction motor. 7

(b) A 24 pole, 50Hz star connected induction motor has rotor resistance of  $0.016\Omega$  per phase and rotor reactance of  $0.0265\Omega$  per phase at standstill. It is achieving its full load torque at a speed of 247 rpm. Calculate the ratio of . 8

- (i) Full load torque to maximum torque  
 (ii) Starting torque to maximum torque.

3. (a) State and explain voltage and current relations for long shunt compound motor and short shunt compound motor. 7

(b) A 230V dc shunt motor runs at 800rpm and takes armature current of 50A. Find resistance to be added to the field circuit to increase current of 80A. Assume flux proportional to field current. Armature resistance =  $0.15\Omega$  & Field resistance =  $250\Omega$  8

4. (a) Explain the principle of operation of capacitor start and capacitor run single phase induction motor. along with the torque-slip characteristics and the applications. 8

(b) Explain the construction and working of bipolar brushless dc motor. 7

[TURN OVER]

**Q.P. Code : 548301**

**2**

5. (a) Explain construction and working of multistack variable reluctance stepper motor.

(b) Explain the construction and working of switched reluctance motor. **8**

6. Write short notes on **15**

(a) DC series motor starter

(b) Autotransformer starter

(c) Split phase induction motor

\_\_\_\_\_

MUPD16460 Sa60 12/28/2016 1:33:52 PM MUPD16460 Sa60 12/28/2016 1:33:52 PM MUPD16460 Sa60 12/28/2016 1:33:52 PM MUPD16460 Sa60 12/28/2016 1:33:52 PM