

Time: 3 Hours

Marks: 80

- Note: 1) Q.1 is **COMPULSORY**.
 2) Attempt **ANY 3 questions** from Q.2 to Q.6
 3) Use of scientific calculators allowed.
 4) Figures to right indicate marks.

Q.1 a) Find the Laplace transform of $e^{-2t} t \cos t$ **(05)**

b) Find the inverse Laplace transform of $\frac{3s+7}{s^2-2s-3}$ **(05)**

c) Determine whether the function $f(z) = (x^3 + 3xy^2 - 3x) + i(3x^2y - y^3 + 3y)$ is analytic and if so find its derivative. **(05)**

d) Find the Fourier series for $f(x) = x^2$ in the interval $(-\pi, \pi)$. **(05)**

Q.2 a) Evaluate $\int_0^\infty \left(\frac{\sin 2t + \sin 3t}{t e^t} \right) dt = \frac{3\pi}{4}$ **(06)**

b) Find the Z- Transform of $\left\{ \left(\frac{1}{4} \right)^{|k|} \right\}$ **(06)**

c) Show that the function $v = e^x(x \sin y + y \cos y)$ is a harmonic function. Find its harmonic conjugate and corresponding analytic function. **(08)**

Q.3 a) From 8 observations the following results were obtained. **(06)**

$$\sum x = 59; \sum y = 40; \sum x^2 = 524; \sum y^2 = 256; \sum xy = 364.$$

Find the equation of the line of regression of x on y and the coefficient of correlation.

b) Find the bilinear transformation which maps the points $z = -1, 0, 1$ onto the points $w = -1, -i, 1$. **(06)**

c) Obtain half-range sine series for $f(x) = (x - 1)^2$ in $0 < x < 1$. Hence find $\sum_{n=1}^\infty \frac{1}{n^2}$ **(08)**

Q.4 a) Find the inverse Laplace Transform by using convolution theorem $\frac{1}{(s^2+a^2)(s^2+b^2)}$ **(06)**

b) Compute Spearman's Rank correlation coefficient for the following data: **(06)**

X	85	74	85	50	65	78	74	60	74	90
Y	78	91	78	58	60	72	80	55	68	70

c) Find the inverse Z-transform for the following; (08)

i) $\frac{1}{(z-5)^2}$, $|z| < 5$ ii) $\frac{z}{(z-2)(z-3)}$, $|z| > 3$

Q.5 a) Using Laplace Transform evaluate $\int_0^\infty e^{-t} (1 + 3t + t^2) H(t - 2) dt$ (06)

b) Prove that $f_1(x) = 1$; $f_2(x) = x$; $f_3(x) = (\frac{3x^2 - 1}{2})$ are orthogonal over $(-1, 1)$. (06)

c) Solve using Laplace transform $\frac{d^2y}{dx^2} - 3\frac{dy}{dx} + 2y = 2e^{3x}$, $y = 2$, $y' = 3$ at $x = 0$. (08)

Q.6 a) Find the complex form of Fourier series for $f(x) = e^x$, $(-\pi, \pi)$. (06)

b) If u , v are harmonic conjugate functions, show that uv is a harmonic function. (06)

c) Fit a straight line of the form $y = a + bx$ to the following data and estimate the value of y for $x = 3.5$ (08)

x	0	1	2	3	4
Y	1	1.8	3.3	4.5	6.3

Duration:3 hours

Total marks:80

- N.S.: (1) Question No.1 is compulsory.**
(2) Solve any three from remaining five questions.
(3) Figures to the right indicate full marks

Q. 1 Answer the following questions: (20)

- (a) Write the entity declaration in VHDL for NOR gate.
- (b) Add $(22)_{10}$ to $(56)_{10}$ in BCD.
- (c) Convert decimal 57 into binary, base 7 and Hexadecimal.
- (d) Construct Hamming code for 1010.
- (e) Perform subtraction using 2's complement for $(10)_{10} - (7)_{10}$
- (f) State and prove De Morgan's law.
- (g) Convert $(77)_{10}$ into Excess-3 code.
- (h) Perform addition of $(34)_8$ and $(62)_8$
- (i) Find 8's complement of the numbers $(37)_8$ and $(301)_8$
- (j) Explain ASCII code in brief.

Q. 2(a) Simplify the following equation using K map to obtain SOP equation and realize the minimum equation using only NAND gates.

$$F(A,B,C,D) = \sum m(1,2,4,6,9,10,12,14) + d(3,7,13) \quad (10)$$

(b) Implement full adder using 8:1 mux. (10)

Q. 3(a) Obtain the minimal expression using QuineMc-Cluskey method (10)

$$F(A,B,C,D) = \sum m(1,2,3,5,6,10,11,13,14) + d(4,7) \quad (10)$$

(b) What is race around condition? How to overcome it? (10)

Q. 4(a) Design 3 bit asynchronous counter and draw the timing diagram. (10)

(b) Convert JK flipflop to SR flipflop and D flipflop. (10)

Q. 5(a) Compare TTL and CMOS with respect to different parameters. (10)

(b) Explain the features of VHDL and its modeling styles. (10)

Q. 6 Write short notes on (any four) (20)

- a) Moore and Mealy machine
- b) Sequence generator
- c) Universal shift register
- d) Priority encoder
- e) Carry look ahead adder

Duration: 3hrs

[Total Marks: 80]

- 1) Question **no.1** is **compulsory**.
- 2) Solve any **three** questions out of remaining **five** questions.
- 3) All questions carry equal marks as indicated by figures to the right.
- 4) Assume appropriate data whenever required. State all assumptions clearly.

Q.1 a) Prove by induction that the sum of the cubes of three consecutive numbers is divisible by 9. (05M)

b) Find the generating function for the following finite sequences (05M)

- i) 2,2,2,2,2,2 ii) 1,1,1,1,1,1

c) A box contains 6 white balls and 5 red balls. In how many ways 4 balls can be drawn from the box if, i) they are to be of any color ii) all the balls to be of the same color. (05M)

d) Find the complement of each element in D_{30} . (05M)

Q.2 a) Define Isomorphism of graphs. Find if the following two graphs are isomorphic. If yes, find the one-to-one correspondence between the vertices. (08M)

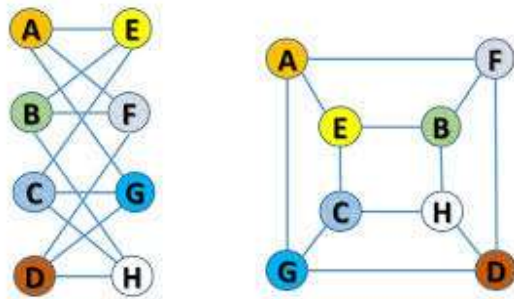

b) In a certain college 4% of the boys and 1% of the girls are taller than 1.8 mts. Furthermore 60% of the students are girls. If a student selected at random is taller than 1.8 mts, what is the probability that the student was a boy? Justify your answer (08M)

c) Prove $\neg(p \vee (\neg p \wedge q))$ and $\neg p \wedge \neg q$ are logically equivalent by developing a series of logical equivalences.

Q. 3 a) Prove that set $G = \{1,2,3,4,5,6\}$ is a finite abelian group of order 6 with respect to multiplication module 7. (08M)

b) Let $A = \{1,2,3,4,5\}$, let $R = \{(1,1), (1,2), (2,1), (2,2), (3,3), (3,4), (4,3), (4,4), (5,5)\}$ and $S = \{(1,1), (2,2), (3,3), (4,4), (4,5), (5,4), (4,5)\}$ be the relations on A. Find the smallest equivalence relation containing the relation R and S. (08M)

c) Test whether the following function is one-to-one, onto or both. (04M)

$$f: \mathbb{Z} \rightarrow \mathbb{Z}, f(x) = x^2 + x + 1$$

Q.4 a) Show that the (2,5) encoding function $e: B^2 \rightarrow B^5$ defined by (08M)

$$e(00) = 00000 \quad e(01) = 01110$$

$$e(10) = 10101 \quad e(11) = 11011$$

is a group code.
How many errors will it detect and correct?

b) Let $H =$

$$\begin{pmatrix} 1 & 0 & 0 \\ 0 & 1 & 1 \\ 1 & 1 & 1 \\ 1 & 0 & 0 \\ 0 & 1 & 0 \\ 0 & 0 & 1 \end{pmatrix}$$

Be a parity check matrix. Determine the group code $e_H: B^3 \rightarrow B^6$ (08M)

c) How many friends must you have to guarantee that at least five of them will have birthdays in the same month? (04M)

Q.5 a) Let G be a set of rational numbers other than 1. Let $*$ be an operation on G defined by $a*b = a + b - ab$ for all $a, b \in G$. Prove that $(G, *)$ is a group.

b) Solve $a_r - 7a_{r-1} + 10a_{r-2} = 6 + 8r$ given $a_0 = 1, a_1 = 2$ (08M)

c) Let $A = \{a, b, c, d, e, f, g, h\}$. Consider the following subsets of A (04M)

$$\begin{aligned} A_1 &= \{a, b, c, d\} & A_2 &= \{a, c, e, g, h\} \\ A_3 &= \{a, c, e, g\} & A_4 &= \{b, d\} & A_5 &= \{f, h\} \end{aligned}$$

Determine whether following is partition of A or not. Justify your answer.

i) $\{A_1, A_2\}$ ii) $\{A_3, A_4, A_5\}$

Q.6 a) Draw the Hasse Diagram of the following sets under the partial order relation divides and indicate which are chains. Justify your answers. (08M)

- I. $A = \{2, 4, 12, 24\}$
- II. $A = \{1, 3, 5, 15, 30\}$

b) Let the functions $f, g,$ and h defined as follows: (08M)

$$f: \mathbb{R} \rightarrow \mathbb{R}, f(x) = 2x + 3$$

$$g: \mathbb{R} \rightarrow \mathbb{R}, g(x) = 3x + 4$$

$$h: \mathbb{R} \rightarrow \mathbb{R}, h(x) = 4x$$

Find $\text{gof}, \text{fog}, \text{foh}, \text{gofoh}$

c) Determine Euler Cycle and path in graph shown below

(04M)

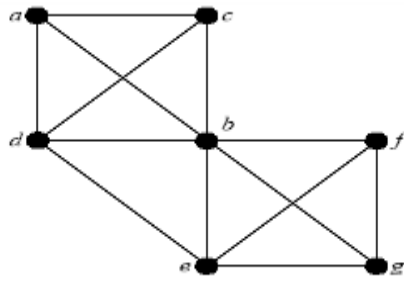

- N.S.: (1) Question No.1 is compulsory.
 (2) Solve any three from remaining five questions.
 (3) Figures to the right indicate full marks

- Q1. A. Draw input & output characteristics of BJT. State significance of DC load line. 5
 B. For an AM DSBFC modulator with carrier frequency $f_c = 100\text{kHz}$ and a maximum modulating signal frequency $f_m = 5\text{kHz}$, determine 5
 i) Frequency limits for the upper and lower side bands
 ii) Bandwidth
 iii) Draw the frequency spectrum
 C. Write a note on zero crossing detector using op-amp with waveforms 5
 D. Compare Class A and Class C Amplifiers 5
- Q2. A. Explain Superheterodyne receiver with suitable diagram 5
 B. Implement summing Operational Amplifier using inverting configuration of Op-amp 5
 C. For the emitter bias network of figure below, determine: 10
 (a) I_b . (b) I_c . (c) V_{ce} . (d) V_c . (e) E_{th} (f) R_{th}

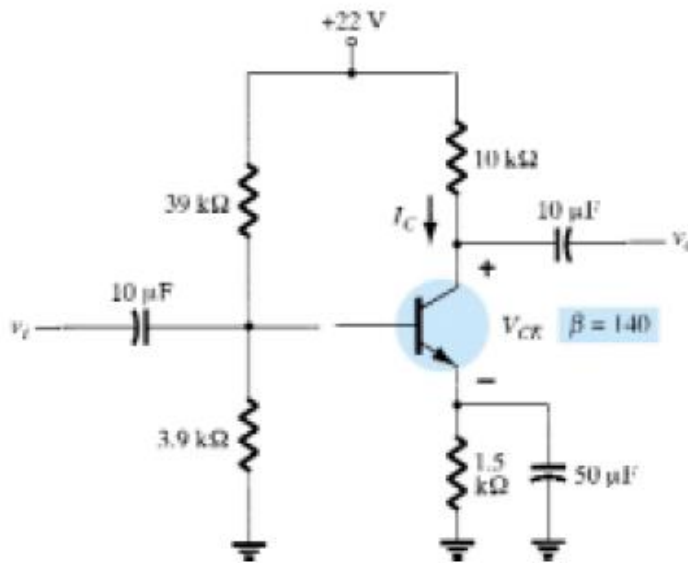

- Q3. A. Explain generation of DSBSC using balanced Modulator along with its frequency and power spectrum 10
 B. With suitable waveforms explain how Op-amp can be used as Differentiator 10
- Q4. A. For an AM DSBFC envelope with $V_{max} = 20\text{V}$ and $V_{min} = 4\text{V}$; determine: 10
 i. Peak amplitude of USF AND LSF
 ii. Peak amplitude of carrier
 iii. Peak change in the amplitude of envelope
 iv. Modulation coefficient
 v. Draw the AM Envelope

- B. Differentiate between TDM and FDM 5
- C. State Shannon's Theorem and explain its significance 5

- Q5. A. Draw PAM, PWM and PPM waveforms in time domain using a sinusoidal signal and explain in brief. 10

- B. Define and explain in brief Amount of information, average information, information rate and Channel capacity of a communication system 10

- Q6. A. State significance of modulation in Communication 5
- B. Write a note on Pulse Code Modulation with waveforms 5
- C. Explain and give ideal values of following parameters of an Op-Amp: 10
 - i. CMRR
 - ii. Slew rate
 - iii. Offset voltage
 - iv. Input Resistance
 - v. Output Impedance

Time: 3 Hours

Marks: 80

- N.B: (1) Question No.1 is compulsory
 (2) Attempt any three questions of the remaining five questions
 (3) Figures to the right indicate full marks
 (4) Make suitable assumptions wherever necessary with proper justifications

- Q.1** (a) Explain different types of data structures with example (05)
 (b) What is a graph? Explain methods to represent graph. (05)
 (c) Write a program in 'C' to implement Merge sort. (10)
- Q.2** (a) Write a program in 'C' to implement QUEUE ADT using Linked-List. Perform the following operations: (10)
 (i) Insert a node in the Queue.
 (ii) Delete a node from the Queue
 (iii) Display Queue elements
- (b) Using Linear probing and Quadratic probing, insert the following values in the hash table of size 10. Show how many collisions occur in each iteration: 28, 55, 71, 67, 11, 10, 90, 44 (10)
- Q.3** (a) Write a program in 'C' to evaluate postfix expression using STACK ADT (10)
 (b) Explain different types of tree traversals techniques with example. Also write recursive function for each traversal technique. (10)
- Q.4** (a) State advantages of Linked-List over arrays. Explain different applications of Linked-list (10)
 (b) Write a program in 'C' to implement Circular queue using arrays. (10)
- Q.5** (a) Write a program to implement Singly Linked List. Provide the following operations: (10)
 (i) Insert a node at the specified location.
 (ii) Delete a node from end
 (iii) Display the list
- (b) Insert the following elements in AVL tree: 44, 17, 32, 78, 50, 88, 48, 62, 54. Explain different rotations that can be used. (10)
- Q.6** Explain the following (any two) (20)
 (a) Splay Tree and Trie
 (b) Graph Traversal Techniques
 (c) Huffman Encoding
 (d) Double Ended Queue
