

Total Marks: 80

Time Duration: 3Hr

- N.B.:1) Question no.1 is compulsory.
2) Attempt any three questions from Q.2 to Q.6.
3) Figures to the right indicate full marks.

Maximum
Marks

- Q1. a) Find the Laplace transform of $\frac{1}{t} e^{-t} \sin t$. [5]
b) Find the inverse Laplace transform of $\frac{1}{\sqrt{2s+1}}$. [5]
c) Show that the function $f(z) = \sinh z$ is analytic and find $f'(z)$ in terms of z . [5]
d) Find the Fourier series for $f(x) = x$ in $(0, 2\pi)$. [5]

- Q2. a) Use Laplace transform to prove $\int_0^{\infty} e^{-t} \frac{\sin^2 t}{t} dt = \frac{1}{4} \log 5$. [6]
b) If $\{f(k)\} = \begin{cases} 4^k, & k < 0 \\ 3^k, & k \geq 0 \end{cases}$, find $Z\{f(k)\}$. [6]
c) Show that the function $u = \cos x \cosh y$ is a harmonic function. Find its harmonic conjugate and corresponding analytic function. [8]

- Q3. a) Find the equation of the line of regression of Y on X for the following data. [6]

X	5	6	7	8	9	10	11
Y	11	14	14	15	12	17	16

- b) Find the bilinear transformation which maps the points 1, -i, 2 on z-plane onto 0, 2, -i respectively of w-plane. [6]

- c) Find half range sine series for $f(x) = \begin{cases} x, & 0 < x < \frac{\pi}{2} \\ \pi - x, & \frac{\pi}{2} < x < \pi \end{cases}$, Hence find the sum of [8]

$$\sum_{(2n-1)}^{\infty} \frac{1}{n^4}$$

- Q4. a) Find the inverse Laplace transform by using convolution theorem $\frac{1}{(s-a)(s+a)^2}$. [6]

- b) Calculate the coefficient of correlation between X and Y from the following data. [6]

X	8	8	7	5	6	2
Y	3	4	10	13	22	8

- c) Find the inverse Z-transform of [8]

i) $\frac{1}{(z-a)^2} \quad |z| < a$

ii) $\frac{1}{(z-3)(z-2)} \quad |z| > 3$

Q5.a) Using Laplace transform evaluate $\int_0^{\infty} e^{-t} (1 + 2t - t^2 + t^3) H(t - 1) dt$. [6]

b) Show that set of functions $\cos x, \cos 2x, \cos 3x \dots$ Is a set of orthogonal functions over $[-\pi, \pi]$. Hence construct a set of orthonormal functions. [6]

c) Solve using Laplace transform $(D^3 - 2D^2 + 5D)y = 0$, with $y(0) = 0, y'(0) = 0, y''(0) = 1$. [8]

Q6.a) Find the complex form of Fourier series for $f(x) = 2x$ in $(0, 2\pi)$. [6]

b) If $f(z)$ and $\overline{f(z)}$ are both analytic, prove that $f(z)$ is constant. [6]

c) Fit a curve of the form $y = ab^x$ to the following data. [8]

X	1	2	3	4	5	6
Y	151	100	61	50	20	8

(3 Hours)

[Max. Marks 80]

- N.B. (1) Question No. 1 is compulsory
 (2) Assume suitable data if necessary
 (3) Attempt any three questions from remaining questions

1

- (a) Convert $(1762.46)_{10}$ into octal, binary and hexadecimal. **(3)**
- (b) Prove OR-AND configuration is equivalent to NOR-NOR configuration. **(3)**
- (c) Perform Subtraction using 16's complement. **(4)**
 - i) $(CB1)_{16} - (971)_{16}$
 - ii) $(426)_{16} - (DBA)_{16}$
- (d) Find 8's complement of following numbers. **(2)**
 - i) $(27)_8$ ii) $(321)_8$
- (e) Perform following subtraction $(52)_{10} - (65)_{10}$ using 2's complement method. **(2)**
- (f) Write the hamming code for 1010. **(2)**
- (g) Implement the following Boolean equation using NAND gates only. **(2)**
 $Y = AB + CDE + F$
- (h) Explain the term prime implicant. **(2)**

- 2** (a) Design a 4-bit ripple adder. **(10)**
- (b) Obtain the minimal expression using Quine Mc-Cluskey method **(10)**
 $F(A,B,C,D) = \sum m (1, 5, 6, 12, 13, 14) + d(2, 4,)$

- 3** (a) Implement a full adder using 8: 1 multiplexer. **(10)**
- (b) Implement the following functions using demultiplexer. **(5)**
 $F1(A, B, C) = \sum m (0, 3, 7)$ $F2(A, B, C) = \sum m (1, 2, 5)$
- (c) Simplify $F(A, B, C, D) = \prod M (3, 4, 5, 6, 7, 10, 11, 15)$ and implement using minimum number of gates. **(5)**

- 4** (a) Compare TTL and CMOS logic with respect to fan in, fan out, propagation delay, power consumption, noise margin, current and voltage parameters. **(5)**
- (b) Draw the circuit for S-R flip flop using two NOR gates and write the architecture body for the same using structural modelling. **(5)**
- (c) Explain 1-digit BCD Adder. **(10)**

- 5** (a) Convert JK flip flop to SR flip flop and D flip flop. **(10)**
- (b) Design 3 bit synchronous counter using T flip flops. **(10)**

- 6** Write short note on **(any four)** **(20)**
 - (a) State table
 - (b) ALU IC 74181
 - (c) Sequence Generator
 - (d) Data flow modelling
 - (e) 4-bit ring counter

(3 Hours)

[Total Marks: 80]

1. Question No. 1 is compulsory.
2. Attempt any three out of the remaining five questions.
3. Assume suitable data if necessary
4. Figures to right indicate full marks.

- Q.1 (a) Prove that $1.1! + 2.2! + 3.3! + \dots + n.n! = (n+1)! - 1$, where n is a positive integer. **[5]**
- (b) Let $A = \{a,b,c\}$. Show that $(P(A), \subseteq)$ is a poset and draw its Hasse diagram. **[5]**
- (c) Explain the terms : - (i) Lattice **[5]**
 (ii) Poset
 (iii) Normal Subgroup
 (iv) Group
 (v) Planar Graph
- (d) Comment whether the function f is one to one or onto. **[5]**
 Consider function: $f: \mathbb{N} \rightarrow \mathbb{N}$ where \mathbb{N} is set of natural numbers including zero.

$$f(j) = j^2 + 2$$

- Q.2 (a) Find the number of ways a person can distribute Rs. 601 as pocket money to his three sons, so that no son should receive more than the combined total of the other two. (Assume no fraction of a rupee is allowed.) **[6]**
- (b) Let $A = \{a_1, a_2, a_3, a_4, a_5\}$ and let R be a relation on A whose matrix is **[6]**

$$M_R = \begin{pmatrix} 1 & 0 & 0 & 1 & 0 \\ 0 & 1 & 0 & 0 & 0 \\ 0 & 0 & 0 & 1 & 1 \\ 1 & 0 & 0 & 0 & 0 \\ 0 & 1 & 0 & 0 & 1 \end{pmatrix}$$

Find M_R^* by Warshall's algorithm.

- (c) Find the complete solution of the recurrence relation: [4]
 $a_n + 2 a_{n-1} = n+3$ for $n \geq 1$ and with $a_0 = 3$.

- (d) Let $f: \mathbb{R} \rightarrow \mathbb{R}$ defined as $f(x) = x^3$ and [4]
 $g: \mathbb{R} \rightarrow \mathbb{R}$ defined as $g(x) = 4x^2 + 1$
 Find out $g \circ f, f \circ g, f^2, g^2$

- Q.3 (a) Given that a student had prepared, the probability of passing a certain entrance [6]
 exam is 0.99. Given that a student did not prepare, the probability of passing the
 entrance exam is 0.05. Assume that the probability of preparing is 0.7. The
 student fails in the exam. What is the probability that he or she did not prepare?

- (b) Define equivalence relation with example. Let 'T' be a set of triangles in a plane [6]
 and define R as the set $R = \{(a,b) \mid a, b \in T \text{ and } a \text{ is congruent to } b\}$ then show
 that R is an equivalence relation.

- (c) Let $A=B=\mathbb{R}$, the set of real numbers [4]
 Let $f: A \rightarrow B$ be given by the formula $f(x) = 2x^3 - 1$ and Let $g: B \rightarrow A$ be given by

$$g(y) = \sqrt[3]{\frac{1}{2}y + \frac{1}{2}}$$

Show that f is a bijection between A and B and g is a bijection between B and A.

- (d) Let Z_n denote the set of integers $\{0, 1, 2, \dots, n-1\}$. Let \circ be binary operation on [4]
 z_n such that $a \circ b =$ the remainder of ab divided by n .
 (i) Construct the table for the operation \circ for $n=4$.
 (ii) Show that (Z_n, \circ) is a semigroup for any n .

- Q.4 (a) (i) Among 50 students in a class, 26 got an A in the first examination and 21 got [6]
 an A in the second examination. If 17 students did not get an A in either
 examination, how many students got an A in both examinations?

(ii) If the number of students who got an A in the first examination is equal to that in the second examination, if the total number of students who got an A in exactly one examination is 40 and if 4 students did not get an A in either examination, then determine the number of students who got an A in the first examination only, who got an A in the second examination only, and who got an A in both the examination.

(b) Consider the (2,5) group encoding function [6]

$e : B^2 \rightarrow B^5$ defined by

$$e(00) = 00000 \qquad e(01) = 01110$$

$$e(10) = 10101 \qquad e(11) = 11011$$

Decode the following works relative to a maximum likelihoods decoding function.

- (i) 11110 (ii) 10011 (iii) 10100

(c) (i) Is every Eulerian graph a Hamiltonian? [4]

(ii) Is every Hamiltonian graph a Eulerian?

Explain with the necessary graph.

(d) Given the parity check matrix [4]

$$H = \begin{bmatrix} 1 & 1 & 0 & 1 & 0 & 0 \\ 0 & 1 & 1 & 0 & 1 & 0 \\ 1 & 0 & 1 & 0 & 0 & 1 \end{bmatrix}$$

Find the minimum distance of the code generated by H. How many errors it can detect and correct?

Q.5 (a) Explain Pigeonhole principle and Extended Pigeonhole principle. Show that in [6]

any room of people who have been doing some handshaking there will always be atleast two people who have shaken hands the same number of times.

(b) Determine whether the Poset with the following Hasse diagrams are lattices or [6]

not. Justify your answer.

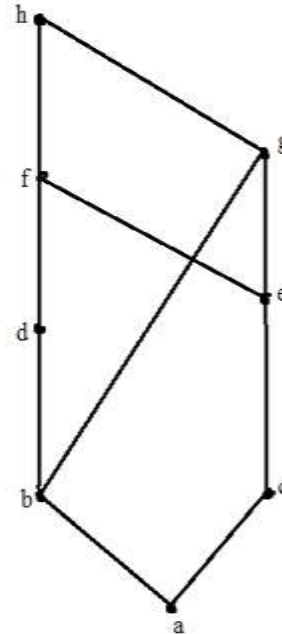
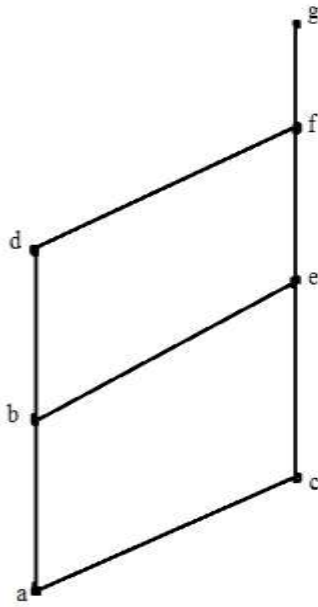

- (c) From the following digraphs, write the relation a set of ordered pairs. Are the relations equivalence relations? [4]

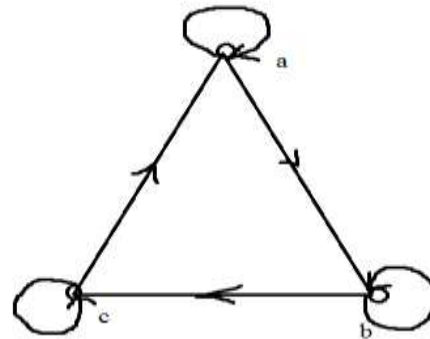
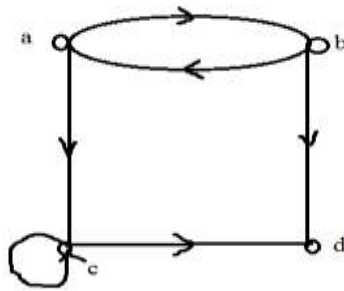

- (d) For the set $X = \{ 2,3,6,12,24,36 \}$, a relation \leq is defined as $x \leq y$ if x divides y . [4]
 Draw the Hasse diagram for (X, \leq) . Answer the following:

- (i) What are the maximal and minimal elements?
- (ii) Give one example of chain & antichain.
- (iii) Is the poset a lattice?

Q.6 (a) Prove that the set $\{1,2,3,4,5,6\}$ is group under multiplication modulo 7. [6]

(b) Given a generating function, find out corresponding sequence. [6]

(i) $\frac{1}{3-6x}$

(ii) $\frac{x}{1-5x+6x^2}$

(c) Determine whether following graphs are isomorphic or not. [4]

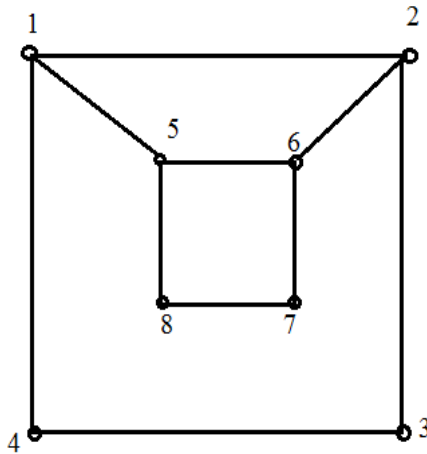

G_1

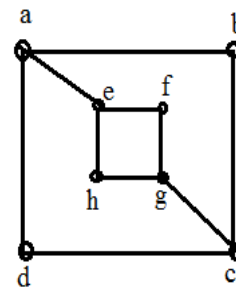

G_2

(d) Prove the following (use laws of set theory) [4]

$$A \times (X \cap Y) = (A \times X) \cap (A \times Y)$$

(3 Hours)

(Total Marks: 80

- N.B. :** 1. Question **ONE** is **compulsory**.
 2. Solve any **THREE** out of remaining questions.
 3. **Draw** neat and **clean diagrams**.
 4. Assume suitable **data** if **required**.

Q. 1. A. What is the source of the leakage current in a transistor?
 If the emitter current of a transistor is 8 mA and I_B is 1/100 of I_C , determine the levels of I_C and I_B . 5

B. Explain the concept of virtual ground in operational amplifiers. 5

C. Draw the spectrum of amplitude modulated wave and explain its components. 5

D. Explain adaptive delta modulation. 5

Q. 2 A. The emitter bias configuration as shown in following figure has the specifications:

$$I_{CQ} = \frac{1}{2} I_{Csat} \quad I_{Csat} = 8 \text{ mA} \quad V_C = 18 \text{ V} \quad \text{and} \quad \beta = 110$$

Determine R_C , R_E and R_B . 10

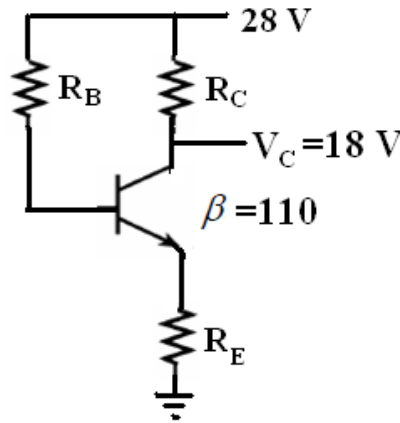

B. Explain the following parameters and their values for 741 opamp
 CMRR, Slew Rate, Gain Bandwidth Product, Input Offset Voltage and
 Output Resistance. 10

TURN OVER

Q. 3 A. Given $\beta=120$ and $I_E= 3.2$ mA for a common-emitter configuration with $r_0=\infty \Omega$, determine:

- (a) Z_i
- (b) A_v if a load of 2 k Ω is applied.
- (c) A_i with the 2 k Ω load.

B. State and explain Barkhausens criteria for oscillations.

C. Explain principle of TDM.

D. Determine the output voltage for the circuit if $V_1=5V$ and $V_2=3V$

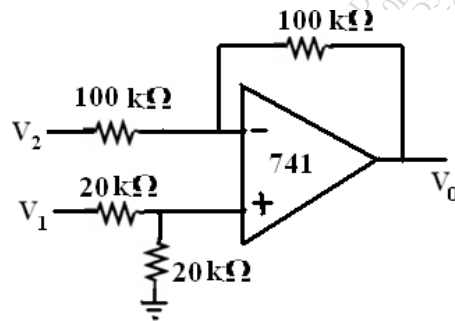

Q. 4 A. Draw the block diagram of phase cancellation SSB generation and explain how the carrier and unwanted sidebands are suppressed.

B. Draw the PAM, PPM and PWM waveforms in time domain assuming a sinusoidal modulating signal. Explain them in brief.

Q. 5 A. State Shannon's theorem on channel capacity.

What is the maximum capacity of a perfectly noiseless channel whose bandwidth is 120 Hz, in which the values of the data transmitted may be indicated by any one of the 10 different amplitudes?

B. With respect to neat diagram explain the elements of analog communication system.

Q. 6 A. What is Nyquist Criteria? What is its significance?

B. Give the proper definition for entropy and information rate.

C. Write short note on op-amp as comparator.

D. Differentiate between Class A and Class C power amplifiers with respect to circuit diagram, operating cycle and power efficiency.

Q.P. Code : 24783

[Time: 3 Hours]

[Marks: 80]

Please check whether you have got the right question paper.

- N.B:
1. Question No.1 is compulsory.
 2. Attempt any three questions of the remaining five questions.
 3. Figures to the right indicate full marks
 4. Make suitable assumptions wherever necessary with proper justifications

- Q.1. a. Explain ADT. List the Linear and Non-linear data structures with example (5)
b. Explain B Tree and B+ Tree. (5)
c. Write a program to implement Binary Search on sorted set of Integers (10)
- Q. 2. a. Write a program to convert Infix expression into Postfix expression. (10)
b. Explain Huffman Encoding with an example (10)
- Q.3. a. Write a program to implement Doubly Linked List. Perform the following operations: (10)
(i) Insert a node in the beginning
(ii) Insert a node in the end.
(iii) Delete a node from the end
(iv) Display the list
b. Explain Topological sorting with example (10)
- Q.4. a. Write a program to implement Quick sort. Show the steps to sort the given numbers: (10)
25, 13, 7, 34, 56,23,13,96,14,2
b. Write a program to implement linear queue using array. (10)
- Q.5. a. Write a program to implement STACK using Linked List. What are the advantages of linked list over array? (10)
b. Write a program to implement Binary Search Tree (BST), Show BST for the following input: (10)
10, 5, 4, 12, 15, 11, 3
- Q.6. Write Short notes on (any two) (20)
(a) AVL Tree
(b) Graph Traversal Techniques
(c) Expression Trees
(d) Application of Linked list- Polynomial Addition.
