

University of Mumbai

Examination 2020 under cluster 4 (Lead College: Pillai College of Engineering)

Examinations Commencing from 15th June 2021 to 26th June 2021

Program: Computer Engineering : SEM VII R2016 scheme CBCGS

Curriculum Scheme: Rev2016

Examination: BE Semester VII

Course Code: CSC703 and Course Name: Artificial Intelligence and Soft Computing

Time: 2 hour

Max. Marks: 80

1301_R16_BE_VII_CSC703_AK1

Q1. Choose the correct option for following questions. All the Questions are compulsory and carry equal marks

Question Number	Correct Option (Enter either 'A' or 'B' or 'C' or 'D')
Q1.	A
Q2.	D
Q3.	A
Q4	B
Q5	C
Q6	A
Q7	C
Q8.	A
Q9.	D
Q10.	D

Q11.	D
Q12.	D
Q13.	D
Q14.	D
Q15.	B
Q16.	C
Q17.	B
Q18.	B
Q19.	C
Q20.	A

Q2. (total-20 Marks)

Descriptive questions

Q2 (A)

Limit = 0  1M

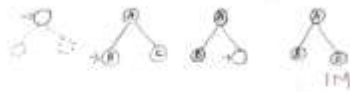
Limit = 1  1M

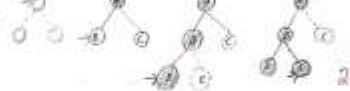
Limit = 2  2M

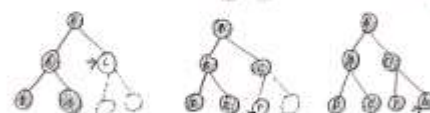

There is some extra cost for generating the successor levels multiple times. 1M

5M

Q2 (B)

Salman likes all kinds of food
 $\forall x \text{ food}(x) \Rightarrow \text{likes}(\text{Salman}, x)$

Apples are foods
 $\text{Apple}(x) \Rightarrow \text{food}(x)$

Chicken is food
 $\text{Chicken}(x) \Rightarrow \text{food}(x)$

Anything anyone eats and is not killed by is food
 $\forall x, y \text{ eat}(x, y) \wedge \neg \text{killed}(y) \Rightarrow \text{food}(x)$

Bill eats peanuts and is still alive
 $\text{eat}(\text{bill}, \text{peanuts}) \wedge \neg \text{killed}(\text{bill})$

Susie eats anything - bill eats 3M
 $\forall x \text{ eat}(\text{bill}, x) \Rightarrow \text{eat}(\text{Susie}, x)$

$\text{likes}(\text{Salman}, \text{peanuts})$
 $\text{food}(x)$
 $\text{eat}(x, y)$ $\neg \text{killed}(y)$
 $\text{eat}(\text{bill}, \text{peanuts})$ $\neg \text{killed}(\text{bill})$ 2M

5M

Q2 (C) PEAS description for Wumpus world

Performance Measure - Points like 1000 for grabbing gold 1M

Environment - describe the same environment 1M

Actuators - actions - Grab, Shoot, Climb 1M

Sensors - Stench, Breeze, Glitter, Bump, Scream 2M

= 5M

Q2 (D) Formulating Vacuum cleaner problem

State - Agent is in one of the two locations 1M

Initial state - 1M

Actions - left, right, suck - 1M

Transition model - 1M

Goal test - 1M

Path cost - 1M

= 5M

Q2 (E)

$R = (\text{good service} \times \text{Sales prod}) \cup (\text{good service} \times \text{Satisfaction grade})$ 1M

Relation $R =$

		5	4	3	2	1
a	1.0	0.8	0.6	0.4	0.2	
b	0.8	0.8	0.6	0.4	0.2	
c	0.6	0.6	0.6	0.4	0.4	
d	0.6	0.6	0.6	0.5	0.6	
e	0.8	0.8	0.8	0.8	0.8	

2M

By applying generalized Modus ponens
 $\text{Very Satisfied} = \text{Very good service} * R$ 3M

Conclusion 'Customer is very satisfied' is defined by
 fuzzy set $\text{Very Satisfied} = \frac{0.4}{1} + \frac{0.4}{2} + \frac{0.6}{3} + \frac{0.8}{4} + \frac{0.8}{5}$
 = 5M

Q2 (F)

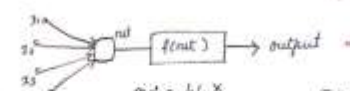
 1M

$\text{net} = W \cdot X$
 $= [1 \ 2 \ 3 \ 4] \begin{bmatrix} 4 \\ 1 \\ 1 \\ 1 \end{bmatrix}$ 2M

$= 4 + 10 + 18 + 28$
 $= 60$
 $f(\text{net}) = 2 * \text{net} = 2 * 60 = 120$ 1M

5M

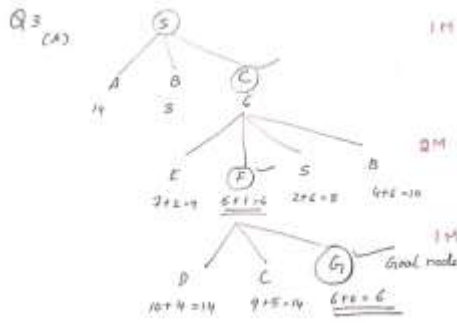

Path - $S \rightarrow C \rightarrow P \rightarrow G$ 1M
5M

- Q3 (B)
- V_x , likes(x, McDonalds) \vee tallen(x, McDonalds) } - 1M
 - V_x , tallen(x, McDonalds) \Rightarrow likes(x, McDonalds) } - 1M
 - $V_{x,y}$ (sibling(x,y) \leftrightarrow sibling(y,x)) - 1M
 - $V_{x,y}$ mother(x,y) \leftrightarrow (female(x) \wedge parent(x,y)) - 1M
 - $V_{x,y}$ first cousin(x,y) \leftrightarrow $\exists p, p_2$ parent(p, x) \wedge sibling(p, p2) \wedge parent(p, y) - 1M
 - $\exists x \forall y$ loves(x,y) - 1M
- 5M

Q3 (C) Single layer NN
 Neurons arranged in 2 layers input & output
 Synapse links or weights
 diagram
 Multiple layers
 L intermediate / hidden layers
 L weights
 L diagram

Q3 (D) Zadeh's interpretation of fuzzy rule.
 $R = (A \times B) \cup (A' \times C)$ 1M
 $R = (\text{long distance} \times \text{high speed}) \cup (\text{long distance} \times \text{moderate speed})$

	30	50	70	90	100
100	0.1	0.5	0.1	0.1	0.1
500	0.1	0.3	0.3	0.3	0.3
1000	0.1	0.3	0.5	0.7	0.7
5000	0.1	0.3	0.5	0.7	0.7

	30	50	70	90	100
100	0.2	0.8	0.6	0.4	0.6
500	0.3	0.7	0.6	0.4	0.6
1000	0.3	0.3	0.5	0.3	0.4
5000	0.0	0.3	0.0	0.0	0.0

$\therefore R =$

	30	50	70	90	100
100	0.3	0.8	0.6	0.4	0.6
500	0.3	0.7	0.6	0.4	0.6
1000	0.3	0.3	0.5	0.7	0.7
5000	0.1	0.3	0.5	0.7	0.7

5M

Q3 (E) Importance of neural networks
 Applications - examples -

Q3 (F) Need for soft computing
 Difference b/w hard computing & SC
 Examples.

2M
5M
 1M
 3M
 1M
5M

University of Mumbai

Examination 2020 under cluster 4 (Lead College: Pillai College of Engineering)

Examinations Commencing from 15th June 2021 to 26th June 2021

Program: Computer Engineering : SEM VII R2016 scheme CBCGS

Curriculum Scheme: Rev2016

Examination: BE Semester VII

Course Code: CSC703 and Course Name: Artificial Intelligence and Soft Computing

Time: 2 hour

Max. Marks: 80

Q1.	Choose the correct option for following questions. All the Questions are compulsory and carry equal marks
1.	Infrared or sonar sensors of an agent, automated drone acting upon the environment in dynamic and stochastic task environments is part of which PEAS description?
Option A:	Sensors
Option B:	Performance Measure
Option C:	Actuators
Option D:	Part of task environment
2.	_____ Agent deals with happy and unhappy state of performance.
Option A:	Learning Agent
Option B:	Simple reflex agent
Option C:	Model based agent
Option D:	Utility based agent
3.	_____ is the process of removing Existential quantifiers by elimination
Option A:	Skolemization
Option B:	AND Elimination
Option C:	Quantification
Option D:	Knowledge Entailment
4.	Which of the following is not a drawback of Hill Climbing Algorithm?
Option A:	Local Maxima
Option B:	Global Maxima
Option C:	Platue
Option D:	Ridge
5.	Which of the following relations hold good for fuzzy sets?
Option A:	$\mu(x)=0$ or 1
Option B:	$\mu(x) \notin [0,1]$
Option C:	$\mu(x) \in [0,1]$
Option D:	It can take any values

6.	_____ and _____ are two kinds of fuzzy quantifiers
Option A:	Absolute and Real
Option B:	Approximate and Real
Option C:	Dummy and Real
Option D:	Precise and Real
7.	<p>Consider fuzzy set M defined on the reference set $U=\{a,b,c,d,e\}$</p> $M = \frac{0.375}{a} + \frac{0.5}{c} + \frac{1.0}{d} + \frac{0.875}{e}$ <p>The Fuzzy set M has core (M) =</p>
Option A:	{a}
Option B:	{c}
Option C:	{d}
Option D:	{e}
8.	<p>Given the stages of an expert system, normally an expert system follows which order of development stages</p> <ol style="list-style-type: none"> i. Develop the prototype ii. Design the system iii. Identify problem domain iv. Test and refine the prototype
Option A:	iii ii i and iv
Option B:	i ii iii and iv
Option C:	iii ii iv and i
Option D:	iv iii ii and i
9.	Which of the below is not an application of an expert system
Option A:	DENDRAL
Option B:	MYCIN
Option C:	CaDET
Option D:	A* SEARCH
10.	<p>Observe the Image and select the linear separable dataset</p> <p>Legend: ● Class 1, ● Class 2</p>

Option A:	Fig a
Option B:	Fig b
Option C:	Fig c
Option D:	Fig d
11.	Which of the following parts of a biological neuron is modeled by the weighted interconnections between the input units and the output unit of an artificial neural model ?
Option A:	Dendrite
Option B:	Axon
Option C:	Soma
Option D:	Synapse
12.	Which of the following is not true about McCulloch Pitts neurons?
Option A:	The interconnections are unidirectional
Option B:	The excitatory interconnections have the same weight
Option C:	All inhibitory connections have the same weight
Option D:	The activation is bipolar
13.	In case of A* search technique, which of the following is not TRUE?
Option A:	A* ensures completeness property
Option B:	A* provides optimal solution to problem
Option C:	if A* has admissible heuristic function, then tree search is optimal
Option D:	It uses small memory & does not visit same node again and again
14.	When a sentence is represented as conjunction of clauses where each clause is disjunction of literals, then the form is called as
Option A:	Bilateral Normal Form
Option B:	Disjunctive Normal Form
Option C:	Clause Normal form
Option D:	Conjunctive Normal Form
15.	The definition of Artificial Intelligence "Computational Intelligence is the study of the design of intelligent agents." (Poole <i>et al.</i> , 1998), falls under which category of AI definition
Option A:	Think like humans
Option B:	Acting rationally
Option C:	Acting humanly
Option D:	Think rationally
16.	In the below figure, identify the depth of Depth First Search Limit from start to goal node?

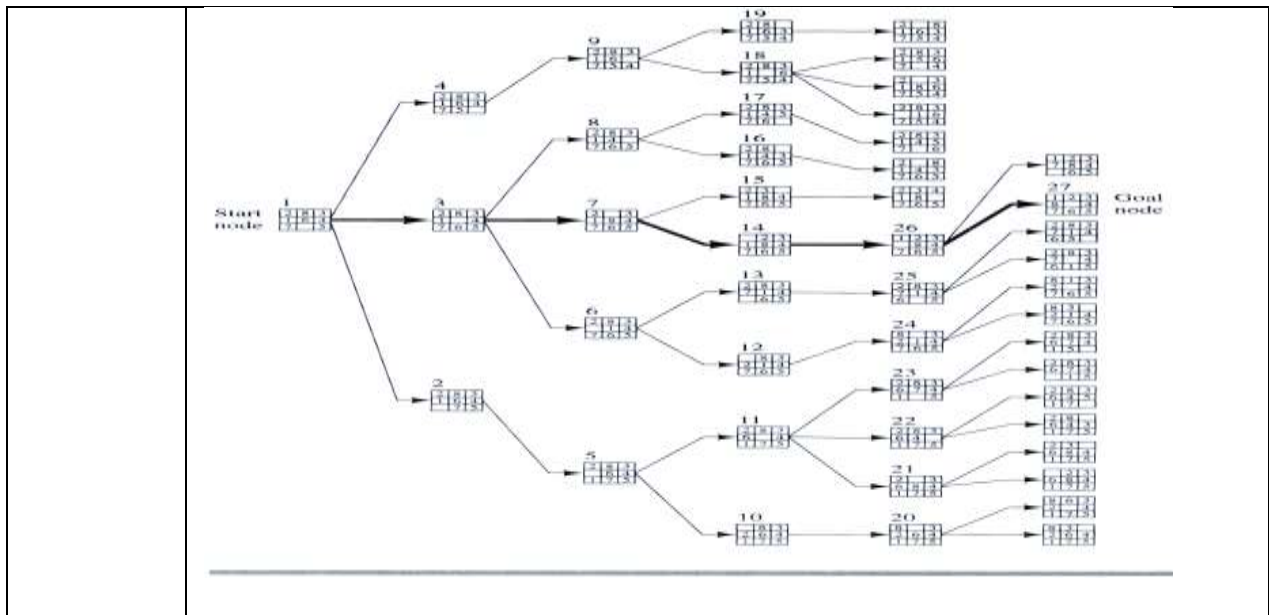

Option A:	L=4
Option B:	L=5
Option C:	L=6
Option D:	L=7
17.	Search strategies are very essential in solving problems. The blind search strategy is one such problem-solving strategy which is also called as
Option A:	Dynamic search strategy
Option B:	Uniform search strategy
Option C:	Uninformed search strategy
Option D:	Informed search strategy
18.	_____ is used to improve the performance of heuristic search.
Option A:	Quality of nodes
Option B:	Quality of heuristic function
Option C:	Simple nodes
Option D:	Nothing helps, search is very uncertain
19.	Which of the following is not a component of formulating a problem?
Option A:	Path cost
Option B:	Goal test
Option C:	Cost test
Option D:	Transition model
20.	A partial order planner can generate various solution sequences through different combinations of subsequence solutions. Each of this final solution is called as _____
Option A:	Linearization of the partial order plan
Option B:	Partial order solution
Option C:	Total order solution
Option D:	Order solution

Descriptive questions

<p>Q2. (20 Marks)</p>	<p>Solve any Four out of Six- 5 marks each</p>
<p>A</p>	<div style="text-align: center;"> <pre> graph TD A((A)) --- B((B)) A --- C((C)) B --- D((D)) B --- E((E)) D --- H((H)) D --- I((I)) E --- J((J)) C --- F((F)) C --- G((G)) F --- K((K)) </pre> </div> <p>Apply IDFS algorithm for the above search tree considering A as start node and G as goal node. Note down the drawback of this algorithm.</p>
<p>B</p>	<p>Consider the below facts</p> <p>Salman likes all kinds of food Apples are food Chicken is food</p> <p>Anything anyone eats and is not killed by is food Bill eats peanuts and is still alive Susie eats anything bill eats.</p> <p>Prove that Salman likes peanuts using backward chaining tree.</p>
<p>C</p>	<p>The wumpus world is a cave consisting of rooms connected by passageways. Lurking somewhere in the cave is the wumpus, a beast that eats anyone who enters its room. The wumpus can be shot by an agent, but the agent has only one arrow. Some rooms contain bottomless pits that will trap anyone who wanders into these rooms (except for the wumpus, which is too big to fall in). The only mitigating feature of living in this environment is the possibility of finding a heap of gold. Although the wumpus world is rather tame by modern computer game standards, it makes an excellent test bed environment for intelligent agents.</p> <p>Give PEAS description for the above agent.</p>
<p>D</p>	<p>The vacuum-cleaner agent is so simple that we can describe everything that happens; it's also a made-up world, so we can invent many variations. This particular world has</p>

	<p>just two locations: squares A and B. The vacuum agent perceives which square it is in and whether there is dirt in the square. It can choose to move left, move right, suck up the dirt, or do nothing. One very simple agent function is the following: if the current square is dirty, then suck; otherwise, move to the other square.</p> <p>Formulate the above problem.</p>
E	<p>Apply fuzzy reasoning with the help of generalized modus ponens to derive conclusion “customer is very satisfied” given</p> <p>$U = \{ \text{service-rating} = \{a,b,c,d,e\} \}$ $V = \text{satisfaction-grade} = \{1,2,3,4,5\}$</p> <p>The sequences a,b,c,d,e and 1,2,3,4,5 are in descending and ascending order respectively. The fuzzy sets good service and satisfied are given below.</p> <p>good-service = 1.0 0.8 0.6 0.4 0.2 ----- + ----- + ----- + ----- + ----- a b c d e</p> <p>satisfied = 0.2 0.4 0.6 0.8 1.0 ----- + ----- + ----- + ----- + ----- 1 2 3 4 5</p> <p>Very-good-service = 0.8 0.6 0.4 0.0 0.0 ----- + ----- + ----- + ----- + ----- 1 2 3 4 5</p>
F	<p>A neuron with four inputs has the weight vector $W = [1 \ 2 \ 3 \ 4]$. The activation function is linear that is, the activation function is given by $f(\text{net}) = 2 * \text{net}$. If the input vector is $X = [4 \ 5 \ 6 \ 7]$ then, find the output of the neuron.</p>

Q3. (20 Marks)	Solve any Four out of Six 5 marks each																		
A	<p>Consider the search problem below with start state S and Goal state G. The transition cost are next to the edges and the heuristic values are as shown in the table. Calculate the final cost using A* search algorithm.</p> <table border="1"> <tr> <th>State</th> <th>S</th> <th>A</th> <th>B</th> <th>C</th> <th>D</th> <th>E</th> <th>F</th> <th>G</th> </tr> <tr> <th>h(n)</th> <td>6</td> <td>8</td> <td>6</td> <td>5</td> <td>4</td> <td>2</td> <td>1</td> <td>0</td> </tr> </table> <p>Table :Heuristic Values – Straight line distance to G</p>	State	S	A	B	C	D	E	F	G	h(n)	6	8	6	5	4	2	1	0
State	S	A	B	C	D	E	F	G											
h(n)	6	8	6	5	4	2	1	0											
B	<p>Convert the following sentences into FOL</p> <ul style="list-style-type: none"> Everyone likes McDonalds unless they are allergic to it 																		

	<ul style="list-style-type: none"> ▪ Sibling is “symmetric” ▪ One’s mother is one’s female parent ▪ A first cousin is a child of a parent’s sibling ▪ “There is a person who loves everyone in the world”
C	Explain single layer feed forward and multilayer feed forward networks.
D	<p>Fuzzy If then else rule R has the form If “x is A” Then “y is B” Else “Y is C”</p> <p>Consider R: If “distance is long” Then “speed is high” Else “speed is moderate”.</p> <p>The relevant sets (crisp and fuzzy) are distance = { 100,500,1000,5000} is the universe of the fuzzy set long distance, speed = { 30,50,70,90,120} is the universe of the fuzzy sets high speed as well as moderate speed, and</p> $\text{Long-distance} = \frac{0.1}{100} + \frac{0.3}{500} + \frac{0.7}{1000} + \frac{1.0}{5000}$ $\text{High-Speed} = \frac{0.1}{30} + \frac{0.3}{50} + \frac{0.5}{70} + \frac{0.7}{90} + \frac{0.9}{120}$ $\text{Moderate-Speed} = \frac{0.3}{30} + \frac{0.8}{50} + \frac{0.6}{70} + \frac{0.4}{90} + \frac{0.1}{120}$ <p>Find “R” by applying Fuzzy If Then Else rule</p>
E	List out the importance of an expert system and give various applications of expert systems in diverse domains.
F	Illustrate the need for soft computing and highlight the differences between soft computing and hard computing by listing few examples of both the computing techniques.

University of Mumbai
Examination 2020 under cluster 04 (Lead College: PCE, Panvel)
Examinations Commencing from 15th June 2021 to 26th June 2021

Program: **Computer Engineering**

Curriculum Scheme: Rev2016

Examination: BE Semester VII

Course Code: CSDLO7031 and Course Name: Advanced System Security and Digital Forensics
Time: 2 hour Max. Marks: 80

=====

Question Number	Correct Option (Enter either 'A' or 'B' or 'C' or 'D')
Q1.	B
Q2.	C
Q3.	B
Q4	C
Q5	D
Q6	A
Q7	A
Q8.	A
Q9.	B
Q10.	C
Q11.	D
Q12.	B
Q13.	A
Q14.	A
Q15.	C
Q16.	A
Q17.	D
Q18.	C
Q19.	A
Q20.	D

Q. 2

A) Explain Bell-LaPadula (BLP) Security Model.

The Bell-La Padula (BLP) model is a model of computer security that focuses on mandatory and discretionary access control.

Read Down

The first goal of the Bell-La Padula security model is to prevent users from gaining access to information above their security clearance. In other words, a user with "Classified" access (a low level clearance) should not be able to read files marked as "Top Secret" (a higher level of secrecy), but someone with "Top Secret Access" should.

Write Up

A malicious program (an interpretation of a subject) might pass classified information along by putting it into an information container labeled at a lower level than the information itself. In other words, there's nothing in the Simple Security Property to stop a malicious Top-Secret level user from reading information in one file, then copying that information into a new file which is able to be read by a user with a lower-level security clearance. Bell & La Padula came up with the "*-property", "a subject at a given security level must not write to any object at a lower security level." In other words, you can only create documents of an equal or higher level security than your access level. This property is called "write up".

Problems with Bell-La Padula: Focus on Confidentiality, not much else., The process of assigning and enforcing security classifications for each file and user is glossed over in the model, and is hard to implement in real life.

Q. 2.

B. Explain Tagged architecture in memory protection with the help of an example

Another problem with using base/bounds registers for protection or relocation is their contiguous nature. Each pair of registers confines accesses to a consecutive range of addresses. A compiler or loader can easily rearrange a program so that all code sections are adjacent and all data sections are adjacent.

An alternative is tagged architecture, in which every word of machine memory has one or more extra bits to identify the access rights to that word. These access bits can be set only by privileged (operating system) instructions. The bits are tested every time an instruction accesses that location. For example, one memory location may be protected as execute-only (for example, the object code of instructions), whereas another is protected for fetch-only (for example, read) data access, and another accessible for modification (for example, write). In this way, two adjacent locations can have different access rights. Furthermore, with a few extra tag bits, different classes of data (numeric, character, address or pointer, and undefined) can be separated, and data fields can be protected for privileged (operating system) access only.

Q. 2.

C. Explain working of SSH

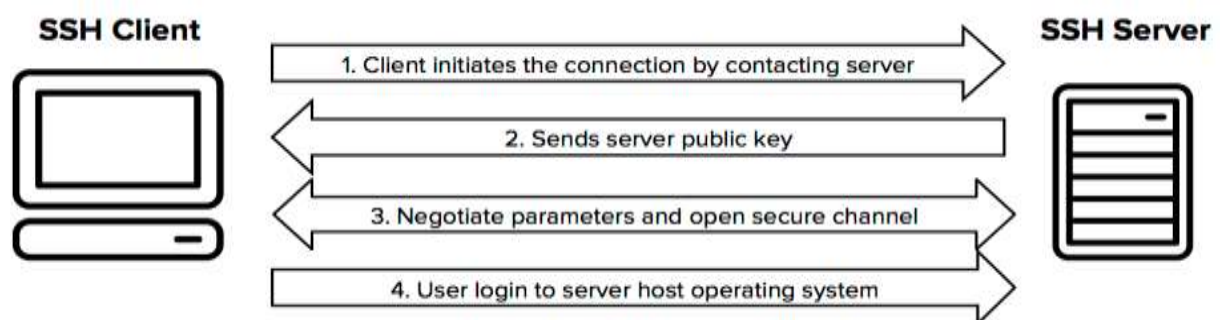

The protocol works in the client-server model, which means that the connection is established by the SSH client connecting to the SSH server. The SSH client drives the connection setup process and uses public key cryptography to verify the identity of the SSH server. After the setup phase the SSH protocol uses strong symmetric encryption and hashing algorithms to ensure the privacy and integrity of the data that is exchanged between the client and server.

Q.2.

D. Describe various authentication mechanisms

Passwords · Tokens · Smart cards · Digital Signatures · Biometric

Q.2.

E. Write a short note WEP

Wired Equivalent Privacy (WEP) is a security standard for wireless networks or WiFi. It was a part of the original IEEE 802.11 protocol. As wireless networks transmit data over radio waves, eavesdropping on wireless data transmissions is relatively easier than in wired networks connected by cables. WEP aims to provide the same level of security and confidentiality in wireless networks as in wired counterparts.

Features of WEP

WEP was introduced as a part of IEEE 802.11 standard in 1997.

It was available for 802.11a and 802.11b devices.

WEP uses encryption of data to make it unrecognizable to eavesdroppers.

It uses RC4, a stream cipher, for encryption and CRC-32 checksum for confidentiality and integrity

The two widely used standards were WEP-40 and WEP-104.

WEP operates at the data link and physical layer.

Q.2.

F. Describe Digital Forensics. Explain the phases of digital forensics process

Digital forensic science is a branch of forensic science that focuses on the recovery and investigation of material found in digital devices related to cybercrime. The term digital forensics was first used as a synonym for computer forensics. Since then, it has expanded to cover the investigation of any devices that can store digital data.

Digital forensics is the process of identifying, preserving, analyzing, and documenting digital evidence. This is done in order to present evidence in a court of law when required.

The digital forensic process has the following five basic stages:

Identification – the first stage identifies potential sources of relevant evidence/information (devices) as well as key custodians and location of data.

Preservation – the process of preserving relevant electronically stored information (ESI) by protecting the crime or incident scene, capturing visual images of the scene and documenting all relevant information about the evidence and how it was acquired.

Collection – collecting digital information that may be relevant to the investigation. Collection may involve removing the electronic device(s) from the crime or incident scene and then imaging, copying or printing out its (their) content.

Analysis – an in-depth systematic search of evidence relating to the incident being investigated. The outputs of examination are data objects found in the collected information; they may include system- and user-generated files. Analysis aims to draw conclusions based on the evidence found.

Reporting – firstly, reports are based on proven techniques and methodology and secondly, other competent forensic examiners should be able to duplicate and reproduce the same results.

Q. 3.

A. Mention different access control policies. Explain in detail DAC and MAC policies

Access Control Policies

An access control policy, which can be embodied in an authorization database, dictates what types of access are permitted, under what circumstances, and by whom. Access control policies are generally grouped into the following categories:

- Discretionary access control (DAC): Controls access based on the identity of the requestor and on access rules (authorizations) stating what requestors are (or are not) allowed to do. This policy is termed discretionary because an entity might have access rights that permit the entity, by its own volition, to enable another entity to access some resource.
- Mandatory access control (MAC): Controls access based on comparing security labels (which indicate how sensitive or critical system resources are) with security clearances (which indicate system entities are eligible to access certain resources). This policy is termed mandatory because an entity that has clearance to access a resource may not, just by its own volition, enable another entity to access that resource.
- Role-based access control (RBAC): Controls access based on the roles that users have within the system and on rules stating what accesses are allowed to users in given roles.
- Attribute-based access control (ABAC): Controls access based on attributes of the user, the resource to be accessed, and current environmental conditions.

Q. 3.

B. Explain various types of malicious programming errors.

Logic Bomb, Virus, Worm, Trojan Horse, Trapdoor, Rabbit, Spyware

Q. 3.

C. Explain SSL architecture

Secure Sockets Layer (SSL)

In SSL, the word socket refers to the mechanism of transferring data between a client and server over a network.

When using SSL for secure Internet transactions, a Web server needs an SSL certificate to establish a secure SSL connection. SSL encrypts network connection segments above the transport layer, which is a network connection component above the program layer.

SSL follows an asymmetric cryptographic mechanism, in which a Web browser creates a public key and a private (secret) key. The public key is placed in a data file known as a certificate signing request (CSR). The private key is issued to the recipient only.

The objectives of SSL are:

Data integrity: Data is protected from tampering.

Data privacy: Data privacy is ensured through a series of protocols, including the SSL Record Protocol, SSL Handshake Protocol, SSL Change CipherSpec Protocol and SSL Alert Protocol.

Client-server authentication: The SSL protocol uses standard cryptographic techniques to authenticate the client and server.

SSL itself is not a single layer protocol in fact it is composed of two sub-layers. Lower sub-layer comprises of the one component of SSL protocol called as SSL Record Protocol. This component provides integrity and confidentiality services. Upper sub-layer comprises of three SSL-related protocol components and an application protocol. Application component provides the information transfer service between client/server interactions. Technically, it can operate on top of SSL layer as well. Three SSL related protocol components are –

SSL Handshake Protocol

Change Cipher Spec Protocol

Alert Protocol.

These three protocols manage all of SSL message exchanges.

Q. 3.

D. Write a short note on Wi-Fi protected access

It was created to patch the security issues of WEP

- It uses Temporal Key Integrity Protocol (TKIP) which provides for key changing dynamically. It replaces WEP without having the need to replace legacy hardware. It encrypts every data packet with a unique key. It hashes the IV and the IV goes out encrypted. It is defined in 802.11i spec.
- It can work with pre-shared keys as well as use 802.1 x authentication
- It uses RC4 stream cipher with a 128 bit key and a 48 bit IV. The longer key and IV together defeat the key recovery attacks on WEP
- It uses RC4 stream cipher with a 128 bit key and a 48 bit IV. The longer key and IV together defeat the key recovery attacks on WEP
- WPA2 is the implementation of IEEE 802.11i. It implements all mandatory features specified in the standard
- WPA can be used for providing more robust security in corporate environments

Q. 3.

E. What is Intellectual Property? Explain types of Intellectual Property.

Intellectual property (IP) refers to creations of the mind, such as inventions; literary and artistic works; designs; and symbols, names and images used in commerce. IP is protected in law by, for example, patents, copyright and trademarks, which enable people to earn recognition or financial benefit from what they invent or create. By striking the right balance between the interests of innovators and the wider public interest, the IP system aims to foster an environment in which creativity and innovation can flourish.

Patent, Copyright, Trademark, Trade Secret

Q. 3.

F. Write short note on Windows Registry

The Windows Registry is a database of settings used by Microsoft Windows. It stores configurations for hardware devices, installed applications, and the Windows operating system. The Registry provides a centralized method of storing custom preferences for each Windows user, rather than storing them as individual .INI files.

The Windows Registry is structured as a hierarchy that has several top-level categories, also known as "hives." Each begins with "HKEY," short for "Handle to Registry Key." Some versions of Windows have as many as seven top-level categories, while Windows 10 has five. These include:

HKEY_CLASSES_ROOT

- stores file associations, which links file extensions to default programs
- stores configurations for COM (Component Object Model) objects, such as Microsoft OLE documents and ActiveX components

HKEY_CURRENT_USER

- stores user-level preferences selected using the Control Panel
- stores user-level network and printer settings

HKEY_LOCAL_MACHINE

- stores system and application settings that apply to all users
- stores system-level network and printer settings

HKEY_USERS

- stores settings temporarily for active users (those who are currently logged in)

HKEY_CURRENT_CONFIG

- stores differences between the standard configuration and the current hardware configuration.

University of Mumbai
Examination 2020 under cluster 04 (Lead College: PCE, Panvel)

Examinations Commencing from 15th June 2021 to 26th June 2021

Program: Computer Engineering

Curriculum Scheme: Rev2016

Examination: BE Semester VII

Course Code: CSDLO7031 and Course Name: Advanced System Security and Digital Forensics
 Time: 2 hour Max. Marks: 80

Q1.	Choose the correct option for following questions. All the Questions are compulsory and carry equal(02) marks
1.	Which of the following is NOT a valid access control mechanism?
Option A:	DAC (Discretionary Access Control) list.
Option B:	SAC (Subjective Access Control) list.
Option C:	MAC (Mandatory Access Control) list.
Option D:	RBAC (Role Based Access Control) list.
2.	Which of the following access control methods relies on user security clearance and data classification?
Option A:	RBAC (Role Based Access Control).
Option B:	NDAC (Non-Discretionary Access Control).
Option C:	MAC (Mandatory Access Control)
Option D:	DAC (Discretionary Access Control).
3.	Which of the following is the best description of access controls?
Option A:	Access controls are a collection of technical controls that permit access to authorized users, systems, and applications.
Option B:	Access controls help protect against threats and vulnerabilities by reducing exposure to unauthorized activities and providing access to information and systems to only those who have been approved.
Option C:	Access control is the employment of encryption solutions to protect authentication information during log-on
Option D:	Access controls help protect against vulnerabilities by controlling unauthorized access to systems and information by employees, partners, and customers
4.	How to overcome the disadvantage of all-or-nothing approach in memory protection
Option A:	Relocation technique
Option B:	Fence method
Option C:	Tagged architecture
Option D:	Base / bound
5.	Trojans can do all of the following except
Option A:	Copying Data
Option B:	Modifying Data
Option C:	Deleting Data
Option D:	Protecting Data

6.	How can fence and relocation be used together?
Option A:	To each program address, the contents of fence register are added.
Option B:	To contents of fence register is subtracted from actual address of program
Option C:	To each program address, the contents of fence register are not added
Option D:	Not possible to use together
7.	In _____ attacks, the attacker manages to get an application to execute an SQL query created by the attacker.
Option A:	SQL Injection
Option B:	Salami
Option C:	Direct
Option D:	Application
8.	SSH uses _____ to authenticate the remote computer.
Option A:	public-key cryptography
Option B:	private-key cryptography
Option C:	any of public-key or private-key
Option D:	both public-key & private-key
9.	Cookies were originally designed for _____
Option A:	Client side programming
Option B:	Server side programming
Option C:	Both Client side programming and Server side programming
Option D:	Socket programming
10.	_____ is a malicious method used by cyber-criminals to trick a user into clicking on something different from what the user wants
Option A:	Click-hacking
Option B:	Click-fraud
Option C:	Clickjacking
Option D:	Using torrent links
11.	_____ type of phishing became very popular as if it has been sent from a legitimate source with a legitimate link to its official website
Option A:	Algo-based phishing
Option B:	Vishing
Option C:	Domain Phishing
Option D:	Email-based phishing
12.	_____ provides an isolated tunnel across a public network for sending and receiving data privately as if the computing devices were directly connected to the private network.
Option A:	Visual Private Network
Option B:	Virtual Private Network
Option C:	Virtual Protocol Networking
Option D:	Both B and C
13.	_____ is a process of wireless traffic analysis that may be helpful for forensic investigations or during troubleshooting any wireless issue

Option A:	Wireless Traffic Sniffing
Option B:	Wi-Fi Traffic Sniffing
Option C:	Wireless Traffic Checking
Option D:	Wireless Transmission Sniffing
14.	Which among the following is the least strong security encryption standard?
Option A:	WEP
Option B:	WPA
Option C:	WPA2
Option D:	WPA3
15.	What protects the intellectual property created by artists?
Option A:	patents
Option B:	trademarks
Option C:	copyright
Option D:	registered designs
16.	In most countries, how long does copyright last for?
Option A:	50 years after the death of the person who created that work
Option B:	10 years after the death of the person who created that work
Option C:	50 years after the creation of the work
Option D:	10 years after the creation of the work
17.	Digital forensics is all of them except:
Option A:	Extraction of computer data
Option B:	Preservation of computer data
Option C:	Interpretation of computer data
Option D:	Manipulation of computer data
18.	What are the three general categories of computer systems that can contain digital evidence?
Option A:	Desktop, laptop, server
Option B:	Hardware, software, networks
Option C:	Open computer systems, communication systems, embedded systems
Option D:	Personal computer, Internet, mobile telephone
19.	Log files are used by the forensic examiner to _____.
Option A:	Associate system events with specific user accounts
Option B:	Verify the integrity of the file system
Option C:	Confirm login passwords
Option D:	Determine if a specific individual is the guilty party
20.	Digital Forensics entails _____.
Option A:	Accessing the system's directories viewing mode and navigating through the various systems files and folders
Option B:	Undeleting and recovering lost files
Option C:	Identifying and solving computer crimes
Option D:	The identification, preservation, recovery, restoration and presentation of digital evidence from systems and devices

Q2	Solve any Four out of Six (5 marks each)
A	Explain Bell-LaPadula (BLP) Security Model
B	Explain Tagged architecture in memory protection with the help of an example
C	Explain working of SSH
D	Describe various authentication mechanisms
E	Write a short note WEP
F	Describe Digital Forensics. Explain the phases of digital forensics process

Q3	Solve any Four out of Six (5 marks each)
A	Mention different access control policies. Explain in detail DAC and MAC policies
B	Explain various types of malicious programming errors.
C	Explain SSL architecture
D	Write a short note on Wi-Fi protected access
E	What is Intellectual Property? Explain types of Intellectual Privacy.
F	Write short note on Windows Registry.

University of Mumbai
Examination 2020 under cluster 4 (Lead College: Pillai College of Engineering)

Examinations Commencing from 15th June 2021 to 26th June 2021

Program: Computer Engineering

Curriculum Scheme: Rev 2016

Examination: BE Semester VII

Course Code: CSDLO7032 and Course Name: Big Data & Analytics

Time: 2 hour

Max. Marks: 80

Question Number	Correct Option (Enter either 'A' or 'B' or 'C' or 'D')
Q1.	C
Q2.	D
Q3.	B
Q4	B
Q5	D
Q6	A
Q7	C
Q8.	B
Q9.	D
Q10.	D
Q11.	A
Q12.	C
Q13.	B
Q14.	D
Q15.	C
Q16.	C
Q17.	B
Q18.	C
Q19.	B
Q20.	C

Q2	Solve any Four out of Six	5 marks each
-----------	----------------------------------	---------------------

A	Mention the 4 characteristics of bigdata. Elaborate these characteristics w.r.to social media websites.																																																												
Ans	4 Characteristics—Volume, Velocity, Variety and Veracity (2 marks) Explanation how social media hold these Vs and generating bigdata (3 marks)																																																												
B	Explain the Map Reduce working and apply the working on the following document. “I like an apple and a banana. He likes an apple and a melon. I also like a melon.”																																																												
Ans	<p>Map Reduce explanation (2 marks) diagram showing flow (1 marks) Example 2 marks</p> <p>Input-> “I like an apple and a banana. He likes an apple and a melon. I also like a melon.”</p> <table border="1" data-bbox="336 781 1452 1581"> <thead> <tr> <th>Map Phase <Key,Value></th> <th>Shuffle and sort</th> <th>Reducer</th> </tr> </thead> <tbody> <tr><td><I,1></td><td><I, [1,1]></td><td><I, 2></td></tr> <tr><td><like,1></td><td><like, [1,1]></td><td><like, 2></td></tr> <tr><td><an,1></td><td><an, [1,1]></td><td><an, 2></td></tr> <tr><td><apple,1></td><td><apple, [1,1]></td><td><apple, 2></td></tr> <tr><td><and,1></td><td><and, [1,1]></td><td><and, 2></td></tr> <tr><td><a,1></td><td><a, [1,1,1]></td><td><a, 3></td></tr> <tr><td><banana,1></td><td><banana, [1]></td><td><banana, 1></td></tr> <tr><td><he,1></td><td><he, [1]></td><td><he, 1></td></tr> <tr><td><likes,1></td><td><likes, [1]></td><td><likes, 1></td></tr> <tr><td><an,1></td><td><melon, [1,1]></td><td><melon, 2></td></tr> <tr><td><apple,1></td><td><also, [1]></td><td><also,1></td></tr> <tr><td><and,1></td><td></td><td></td></tr> <tr><td><a,1></td><td></td><td></td></tr> <tr><td><melon,1></td><td></td><td></td></tr> <tr><td><I,1></td><td></td><td></td></tr> <tr><td><also,1></td><td></td><td></td></tr> <tr><td><like,1></td><td></td><td></td></tr> <tr><td><a,1></td><td></td><td></td></tr> <tr><td><melon,1></td><td></td><td></td></tr> </tbody> </table>	Map Phase <Key,Value>	Shuffle and sort	Reducer	<I,1>	<I, [1,1]>	<I, 2>	<like,1>	<like, [1,1]>	<like, 2>	<an,1>	<an, [1,1]>	<an, 2>	<apple,1>	<apple, [1,1]>	<apple, 2>	<and,1>	<and, [1,1]>	<and, 2>	<a,1>	<a, [1,1,1]>	<a, 3>	<banana,1>	<banana, [1]>	<banana, 1>	<he,1>	<he, [1]>	<he, 1>	<likes,1>	<likes, [1]>	<likes, 1>	<an,1>	<melon, [1,1]>	<melon, 2>	<apple,1>	<also, [1]>	<also,1>	<and,1>			<a,1>			<melon,1>			<I,1>			<also,1>			<like,1>			<a,1>			<melon,1>		
Map Phase <Key,Value>	Shuffle and sort	Reducer																																																											
<I,1>	<I, [1,1]>	<I, 2>																																																											
<like,1>	<like, [1,1]>	<like, 2>																																																											
<an,1>	<an, [1,1]>	<an, 2>																																																											
<apple,1>	<apple, [1,1]>	<apple, 2>																																																											
<and,1>	<and, [1,1]>	<and, 2>																																																											
<a,1>	<a, [1,1,1]>	<a, 3>																																																											
<banana,1>	<banana, [1]>	<banana, 1>																																																											
<he,1>	<he, [1]>	<he, 1>																																																											
<likes,1>	<likes, [1]>	<likes, 1>																																																											
<an,1>	<melon, [1,1]>	<melon, 2>																																																											
<apple,1>	<also, [1]>	<also,1>																																																											
<and,1>																																																													
<a,1>																																																													
<melon,1>																																																													
<I,1>																																																													
<also,1>																																																													
<like,1>																																																													
<a,1>																																																													
<melon,1>																																																													
C	List down at least 4 different sources of bigdata from different domain and justify how they can be considered as bigdata applications.																																																												
Ans	<p>Listing of 4 different sources of big data from different domains (2 marks)</p> <ol style="list-style-type: none"> 1) Social data (all social websites and app) 2) Machine data (sensor, medical devices, satellite etc) 3) Transactional data 4) Log data <p>Justification by using 3V's (Velocity , Variety and volume) (3 marks)</p>																																																												

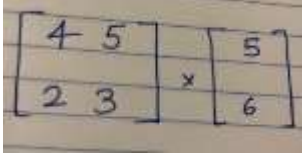
D	<p>Apply Map Reduce Vector Multiplication algorithm to perform the following matrix vector multiplication.</p> 																															
Ans	<p>Map Phase:</p> <p>map (key, value): for (i, j, a_ij) in value: emit (i, a_ij * v[j])</p> <table border="1" data-bbox="336 680 987 945"> <thead> <tr> <th>I</th> <th>j</th> <th>A[i][j]</th> <th>i</th> <th>A[i][j]* V[j]</th> </tr> </thead> <tbody> <tr> <td>1</td> <td>1</td> <td>4</td> <td>1</td> <td>20</td> </tr> <tr> <td>1</td> <td>2</td> <td>5</td> <td>1</td> <td>30</td> </tr> <tr> <td>2</td> <td>1</td> <td>2</td> <td>2</td> <td>10</td> </tr> <tr> <td>2</td> <td>2</td> <td>3</td> <td>2</td> <td>18</td> </tr> </tbody> </table> <p>Reduce Phase: reduce(key, values): result = 0 for value in values: result += value emit(key, result)</p> <table border="1" data-bbox="336 1240 702 1447"> <thead> <tr> <th>I</th> <th>result</th> </tr> </thead> <tbody> <tr> <td>1</td> <td>20+30= 50</td> </tr> <tr> <td>2</td> <td>10+18=28</td> </tr> </tbody> </table> <p>2 marks for map phase +2 marks for reduce phase +1 marks for mentioning map and reduce process in matrix vector multiplication.</p>	I	j	A[i][j]	i	A[i][j]* V[j]	1	1	4	1	20	1	2	5	1	30	2	1	2	2	10	2	2	3	2	18	I	result	1	20+30= 50	2	10+18=28
I	j	A[i][j]	i	A[i][j]* V[j]																												
1	1	4	1	20																												
1	2	5	1	30																												
2	1	2	2	10																												
2	2	3	2	18																												
I	result																															
1	20+30= 50																															
2	10+18=28																															
E	<p>List all variation of NoSQL database with two features of each and two examples of each</p>																															
Ans	<p>i) Key value – Dynamo, Cassandra ii) Graph based – Neo4j, Flock DB iii) Column oriented – Big Table, Hbase iv) Document base- Mongo DB, Couch DB</p> <p>2 marks for listing the names and example and 3 marks for writing the features</p>																															
F	<p>Explain CAP theorem of NoSQL database. As No SQL database is not able to adopt ACID properties can we adopt NoSQL for traditional banking application?</p>																															

	CAP theorem explanation 3 marks (includes diagrammatic representation)
Ans	No. we cannot adopt the No Sql instead of traditional RDBMS in banking applications completely as ACID is must in banking application. We cannot go for eventual consistency in banking application. (2 marks)

Q3	Solve any two out of three	10 marks each																																																							
A	Compare Content based recommendation system with collaborative recommendation. Give an example of Utility Matrix for the most popular movie recommendation system for the user profile and the item profile and mention the methods by which you can find the similar users.																																																								
Ans	<p>Comparison with 4 points----- 4 marks. Movie Recommendation System</p> <p>User profile matrix -----2 marks (It will have few users and list of movies with rating)</p> <table border="1" style="width: 100%; border-collapse: collapse; text-align: center;"> <thead> <tr> <th>User</th> <th>Mission Mangal</th> <th>Uri</th> <th>Coolie No1</th> <th>Dil Bechara ra</th> </tr> </thead> <tbody> <tr> <td>A</td> <td>1</td> <td>1</td> <td>0</td> <td>0</td> </tr> <tr> <td>B</td> <td>1</td> <td></td> <td>0</td> <td>1</td> </tr> <tr> <td>C</td> <td>1</td> <td>1</td> <td>0</td> <td>1</td> </tr> <tr> <td>D</td> <td>0</td> <td>0</td> <td>1</td> <td>1</td> </tr> <tr> <td>E</td> <td>1</td> <td>1</td> <td>0</td> <td>0</td> </tr> </tbody> </table> <p>Sample Item profile matrix-----2 marks (item profile depicts the properties of the item...which helps us to identify why user like the item.)</p> <table border="1" style="width: 100%; border-collapse: collapse; text-align: center;"> <thead> <tr> <th>Movie</th> <th>Genre</th> <th>Actor</th> <th>Actress</th> <th>Director</th> </tr> </thead> <tbody> <tr> <td>Mission Mangal</td> <td>Scientific fiction</td> <td>Akshay Kumar</td> <td>Vidya Balan</td> <td>X</td> </tr> <tr> <td>Uri</td> <td>Patriotic</td> <td></td> <td>--</td> <td>Y</td> </tr> <tr> <td>Coolie no1</td> <td>Comedy</td> <td>Varun Dhawan</td> <td>Xy</td> <td>Z</td> </tr> <tr> <td>Dil bechara</td> <td>Romantic</td> <td>Sushant Sing</td> <td>Pq</td> <td>W</td> </tr> </tbody> </table> <p>Clustering, CPM are the methods with which we can find similar users. (2 marks)</p>		User	Mission Mangal	Uri	Coolie No1	Dil Bechara ra	A	1	1	0	0	B	1		0	1	C	1	1	0	1	D	0	0	1	1	E	1	1	0	0	Movie	Genre	Actor	Actress	Director	Mission Mangal	Scientific fiction	Akshay Kumar	Vidya Balan	X	Uri	Patriotic		--	Y	Coolie no1	Comedy	Varun Dhawan	Xy	Z	Dil bechara	Romantic	Sushant Sing	Pq	W
User	Mission Mangal	Uri	Coolie No1	Dil Bechara ra																																																					
A	1	1	0	0																																																					
B	1		0	1																																																					
C	1	1	0	1																																																					
D	0	0	1	1																																																					
E	1	1	0	0																																																					
Movie	Genre	Actor	Actress	Director																																																					
Mission Mangal	Scientific fiction	Akshay Kumar	Vidya Balan	X																																																					
Uri	Patriotic		--	Y																																																					
Coolie no1	Comedy	Varun Dhawan	Xy	Z																																																					
Dil bechara	Romantic	Sushant Sing	Pq	W																																																					
B	Write the algorithm for Clique Percolation Method. Apply the same to find the communities on the following graph. (Show the stepwise execution of the algorithm).																																																								

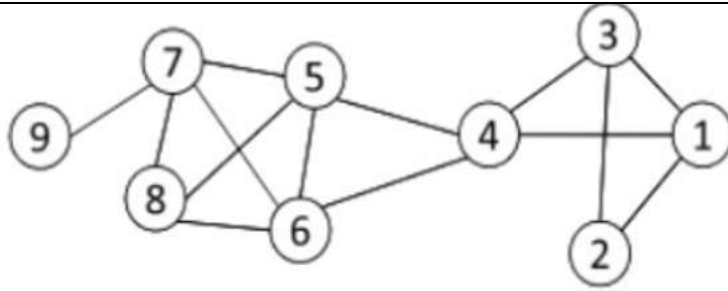

CPM algo -----4 marks

Input :- The social graph G , representing a network and a clique size k .

Output : Set of discovered Communities C

Step1 : All k -clique present in G are extracted

Step 2: A new graph, the clique graph, G_c formed where each node represented an identified clique and two vertices in G_c are connected by an edge, if they have $k-1$ common vertices.

Step 3: Connected components in G_c are identified

Step 4: Each connected component in G_c represents a community.

Step 5: Set C be the set of communities formed for G .

Problem solving -----6 marks (each step 2 marks...Communities should be shown in the end.)

Step 1: Find all Cliques of size 3

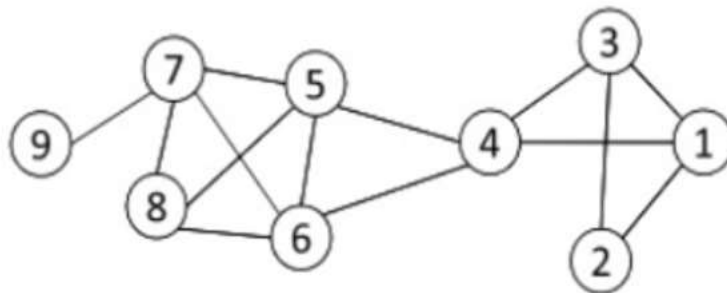

$\{1, 2, 3\}, \{1, 3, 4\}, \{4, 5, 6\}, \{5, 6, 7\}, \{5, 6, 8\}, \{5, 7, 8\},$
 $\{6, 7, 8\}$

Step 2: Construct Clique Graph

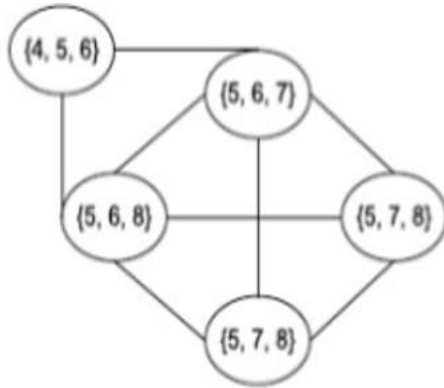
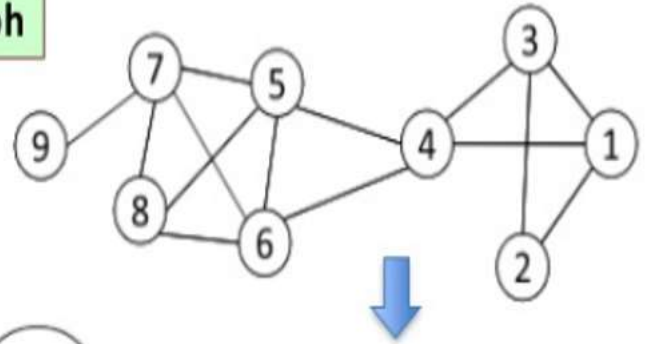

$\{1, 2, 3\}, \{1, 3, 4\}, \{4, 5, 6\},$
 $\{5, 6, 7\}, \{5, 6, 8\}, \{5, 7, 8\},$
 $\{6, 7, 8\}$



Step 3: Finding Communities

Two cliques are adjacent if they share $k-1$ nodes (i.e. $k-1=2$)

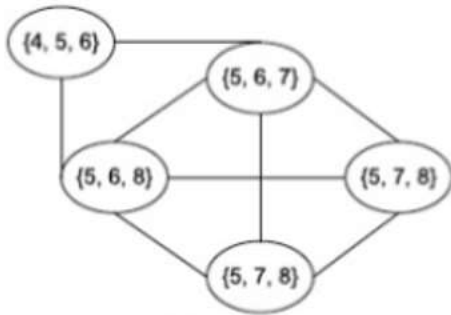
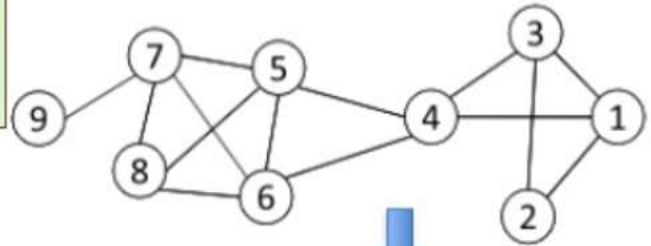

{1, 2, 3}, {1, 3, 4}, {4, 5, 6},
 {5, 6, 7}, {5, 6, 8}, {5, 7, 8},
 {6, 7, 8}

Communities:

{1, 2, 3, 4}
 {4, 5, 6, 7, 8}

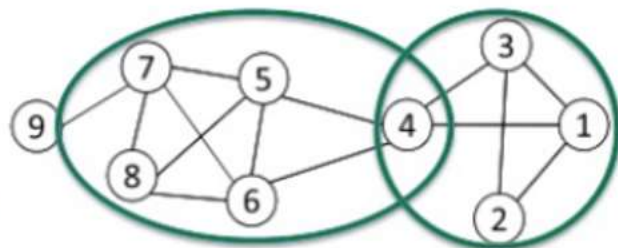

30

C

Consider the stock market stream data. Justify the data stream features and draw the model of data stream management for the mention system. Give two examples of onetime query and continuous query from stock marketing stream.

Ans

Stream Features:

Stream data sets are Continuous, Massive, Unbounded and Possibly infinite. It is fast changing and requires fast, real-time response. (2 marks)

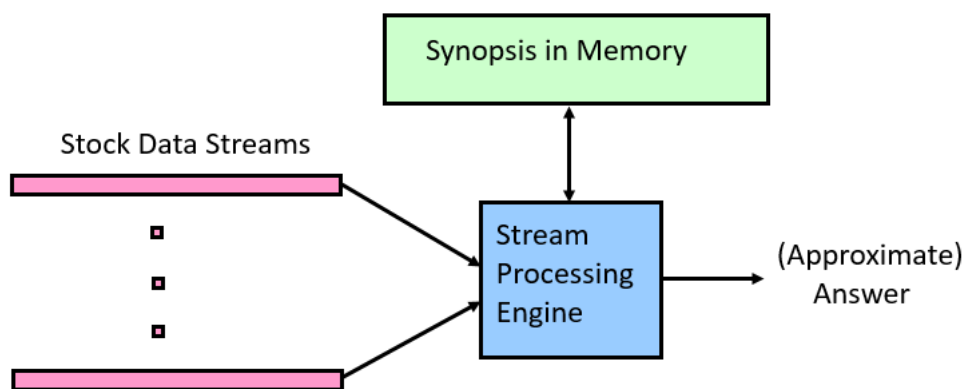

(diagram 2 marks)

Justification how stock data is an example of stream processing w.r.to feature of stream data.
(2 marks)

Examples (4 marks)

One time Query:

Opening value of stock
Closing value of stock

Continuous Query

Max value of the stock in a day/week/month
Min value of the stock in a day/week/month

University of Mumbai

Examination 2020 under cluster 4 (Lead College: Pillai College of Engineering)

Examinations Commencing from 15th June 2021 to 26th June 2021

Program: Computer Engineering

Curriculum Scheme: Rev 2016

Examination: BE Semester VII

Course Code: CSDLO7032 and Course Name: Big Data & Analytics

Time: 2 hour

Max. Marks: 80

Q1.	Choose the correct option for following questions. All the Questions are compulsory and carry equal marks
1.	One Zettabytes is not equal to
Option A:	1 000 000 000 000 000 000 000 Bytes
Option B:	2^{70} bytes
Option C:	10^{22} bytes
Option D:	1000000000 Terabytes
2.	Which is not true in the case of MapReduce paradigm
Option A:	The output of Map function acts as input for Reduce
Option B:	If M represents the number of map functions and N represents the number of reduce function then $M > N$ holds
Option C:	The shuffle and sort is an intermediate state between the Map phase and Reduce Phase
Option D:	Map and Reduce can execute in parallel.
3.	BigTable, Hbase and MongoDB support this two properties from CAP theorem
Option A:	ACID properties
Option B:	CP
Option C:	AP
Option D:	CA
4.	Find the Jaccard similarity between $A=\{1,2,3,4,5,6\}$ $B=\{3,4,5,7,8\}$
Option A:	8/3
Option B:	3/8
Option C:	5/8
Option D:	8/5
5.	Which of the application is not using the nearest neighbor concept
Option A:	Web Search
Option B:	Content based image retrieval
Option C:	Document similarity
Option D:	Finding the average price of stock in a day.
6.	In calculation of page rank which one is more important
Option A:	Backward links

Option B:	Forward links
Option C:	Backward as well as forward link both are equally important
Option D:	Neither backward nor forward link is important.
7.	Which one is not an example of one time query
Option A:	Current value of the temperature sensor located at location x.
Option B:	Opening stock value
Option C:	Total calls made by customer X in a day
Option D:	Closing stock value
8.	The role of Oozie, ZooKeeper and Mahut are respectively
Option A:	Job Workflow, Processing, Coordinator
Option B:	Job Workflow, Coordinator, DM library
Option C:	Data Integration, Coordinator, DM library
Option D:	Data Integration, Processing, Coordinator
9.	Which HDFS command will give error
Option A:	<code>hadoop fs -cp <src> <dest></code>
Option B:	<code>hadoop fs -mv <src> <dest></code>
Option C:	<code>hadoop fs -copyToLocal <hdfs source> <localdest></code>
Option D:	<code>hadoop fs -copyFromLocal <hdfs source> <localdest></code>
10.	DGIM algorithm uses for
Option A:	Check the element is present or not
Option B:	Count the ones in overall stream
Option C:	Check one is present in the stream or not
Option D:	Count the no. of ones in specified sliding window
11.	Traditional database technology is not sufficient to handle the Big Data because of I) generation rate II) need of flexible schema III) no need to handle unstructured data IV) high volume. Choose appropriate
Option A:	Only I, II, and IV
Option B:	Only I, II and III
Option C:	Only I and III
Option D:	I,II,III and IV
12.	Hadoop is not
Option A:	scalable
Option B:	flexible
Option C:	Non-fault tolerant
Option D:	Cost effective
13.	Filtering in data stream is helps to
Option A:	Determine the item is of non-interest and should be store for further evaluation
Option B:	Determine the item is of interest and should be store for further evaluation
Option C:	Determines only the item is of non-interest
Option D:	Determines only the item is of interest
14.	In content based recommendation system for online shopping, system need not have the knowledge of

Option A:	User's like
Option B:	User's previous search
Option C:	User's previous purchase
Option D:	User's contact details
15.	Distance measure possess following property
Option A:	Asymmetric
Option B:	Antisymmetric
Option C:	Symmetric
Option D:	negative
16.	If web structure has the below component it will lead to dead end.
Option A:	SCC and tendrils in component
Option B:	Only SCC
Option C:	Disconnected component
Option D:	Connected component
17.	Which is not true in case of Hadoop Technology
Option A:	Hadoop cluster can be formed using commodity server.
Option B:	Data is sent on those Datanode where task logic/code is available.
Option C:	The default replication factor is 3x.
Option D:	Heartbeat helps to find the status of data node.
18.	CPM is used for specifically
Option A:	Finding communities in social networks
Option B:	Finding disjoint communities in a social network
Option C:	Finding overlapping communities in a social network
Option D:	Finding triangles in a social network.
19.	If expected queries are over more recent data then which sampling technique is more appropriate
Option A:	Reservoir Sampling
Option B:	Biased Reservoir Sampling
Option C:	Concise Sampling
Option D:	Sketching
20.	Google is using.....which is of type.....and Amazon is using.....which is of type.....
Option A:	Big Table, Documentbase, Neo4j graph DBD
Option B:	MongoDB, key value, Dyanmo DB, key value
Option C:	Big Table, Column-oriented, Dynamo, Key-Value
Option D:	Hbase, column-oriented, Dynamo DB, documentbase.

Q2	Solve any Four out of Six	5 marks each
-----------	----------------------------------	---------------------

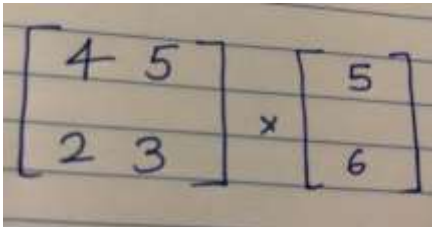
A	Mention the 4 characteristics of bigdata. Elaborate these characteristics w.r.to social media websites.
B	Explain the Map Reduce working and apply the working on the following document. "I like an apple and a banana. He likes an apple and a melon. I also like a melon."
C	List down at least 4 different sources of bigdata from different domains and justify how they can be considered as bigdata applications.
D	Apply Map Reduce Vector Multiplication algorithm to perform the following matrix vector multiplication. 
E	List all variation of NoSQL database with two features of each and two examples of each.
F	Explain CAP theorem of NoSQL database. As No SQL database is not able to adopt ACID properties can we adopt NoSQL for traditional banking application?

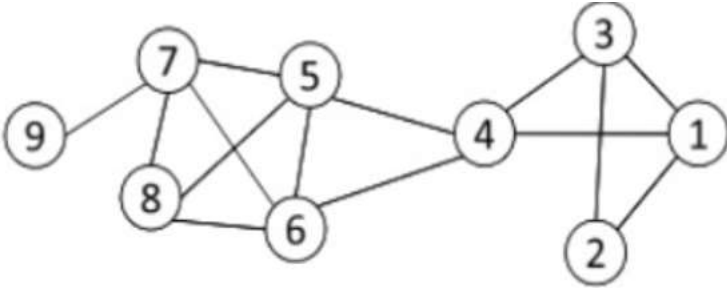
Q3	Solve any two out of three	10 marks each
A	Compare Content based recommendation system with collaborative recommendation. Give an example of Utility Matrix for the most popular movie recommendation system for the user profile and the item profile and mention the method by which you can find the similar users.	
B	Write the algorithm for Clique Percolation Method. Apply the same to find the communities on the following graph. (Show the stepwise execution of the algorithm). 	
C	Consider the stock market stream data. Justify the data stream features and draw the model of data stream management for the mention system. Give two examples of onetime query and continuous query from stock marketing stream.	

University of Mumbai
Examination 2021 under cluster ALL (Lead College: VCET)

Examinations Commencing from 15th June 2021

Program: ALL_Institute Level Optional Course 1

Curriculum Scheme: Rev2016

Examination: BE Semester VII

Course Code: ILO 7016 and Course Name: Cyber Security and Laws

Time: 2 hour

Max. Marks: 80

Question Number	Correct Option (Enter either 'A' or 'B' or 'C' or 'D')
Q1.	D
Q2.	D
Q3.	A
Q4	C
Q5	B
Q6	D
Q7	B
Q8.	C
Q9.	D
Q10.	A
Q11.	C
Q12.	B
Q13.	A
Q14.	C
Q15.	C
Q16.	B
Q17.	B
Q18.	C
Q19.	B
Q20.	D

University of Mumbai
Examination 2021 under cluster ALL (Lead College: VCET)

Examinations Commencing from 15th June 2021

Program: ALL_Institute Level Optional Course 1

Curriculum Scheme: Rev2016

Examination: BE Semester VII

Course Code: ILO 7016 and Course Name: Cyber Security and Laws

Time: 2 hours

Max. Marks: 80

Q1.	Choose the correct option for following questions. All the Questions are compulsory and carry equal marks
1.	Which is not an element of information security ?
Option A:	Confidentiality
Option B:	Integrity
Option C:	Authentication
Option D:	Standardization
2.	Cyber -vandalism is
Option A:	Using cyber-technology in unauthorized ways to reproduce copies of propriety software and proprietary information
Option B:	To distribute proprietary information across a network
Option C:	Using cyber-technology to gain unauthorized access to an individual's or organization's computer system.
Option D:	Using cyber-technology to unleash one or more programs that disrupt the transmission of electronic information across one or more computer networks, including the Internet.
3.	Which of the following is a non-violent cybercrime ?
Option A:	Internet gambling
Option B:	Cyberstalking
Option C:	Piracy
Option D:	Identity theft
4.	By Salami Attack virus we mean:
Option A:	Trapdoors persist
Option B:	Control viruses
Option C:	A small amount of money is shaved from each computation
Option D:	Poor error checking
5.	For attacking the database of a system / website which method is used by the criminals.
Option A:	HTML injection
Option B:	SQL Injection
Option C:	Malicious code injection
Option D:	XML Injection

6.	If you are contacted via telephone by someone posing to represent a financial institution you do business with and are asked to provide or update personal or account information, you should:
Option A:	Give all your confidential and personal data to them
Option B:	Ask to speak to a senior supervisor
Option C:	Hang up!
Option D:	Hang up and find the phone number of that institution in one of your account statements, credit cards or their verifiable website address and call that number to check on the request.
7.	If a user's session is compromised by another person with the intention of either misuse of the user's credentials without his/her knowledge or exploiting the user's data and perform malicious activities is called _____
Option A:	Social engineering
Option B:	Session hijacking
Option C:	Cookie stuffing
Option D:	Baiting
8.	The first step in hacking is _____
Option A:	Remote attack
Option B:	Port scanning
Option C:	Reconnaissance
Option D:	Clear logs
9.	_____ is a technique of hiding confidential information inside a picture?
Option A:	Image processing
Option B:	Stenography
Option C:	Key loggers
Option D:	DoS attack
10.	The purpose of a Denial of Service attack is _____.
Option A:	To overload a system so that it is no longer operational
Option B:	To shutdown services by turning them off
Option C:	To crack the password of a system
Option D:	To assess the vulnerabilities
11.	Comparing the value of the canary with the original value, can help one identify if a _____ has occurred.
Option A:	DDoS
Option B:	Nuking
Option C:	Buffer overflow
Option D:	Block cipher
12.	This type of contract is used for online services like creating a new e-mail account. This contract is known as
Option A:	Shrink wrap contract
Option B:	Click wrap contract
Option C:	Browse wrap contract

Option D:	Void contract
13.	Digital Signature Certificate is _____ requirement under various applications
Option A:	Statutory
Option B:	Legislative
Option C:	Governmental
Option D:	Voluntary
14.	Which of the following cannot be exploited by assigning or by licensing the rights of others.
Option A:	Patent
Option B:	Design
Option C:	Trademark
Option D:	Copyright
15.	Which is the Act which provides legal framework for e-Governance in India
Option A:	IT (amendment) Act 2008
Option B:	Indian Penal Code
Option C:	IT Act 2000
Option D:	Indian Evidence Act, 1872
16.	Which following Act was not amended in Information Technology Act 2000 ?
Option A:	The Bankers Books Evidence Act, 1891
Option B:	BSNL IT Policy
Option C:	RBI Act 1934.
Option D:	The Indian Evidence Act, 1872
17.	The punishment for hacking of computers under ITAA 2008?
Option A:	Fine up to ten lakhs or imprisonment up to three years or both
Option B:	Fine up to five lakhs or imprisonment up to three years or both
Option C:	Fine up to five lakhs or imprisonment up to five years or both
Option D:	Fine up to ten lakhs or imprisonment up to five years or both
18.	Companies are required to disclose on an almost real time basis the information concerning material changes in its financial conditions or operations. Which is this key provision?
Option A:	SOX section 302
Option B:	SOX section 404
Option C:	SOX section 409
Option D:	SOX section 806
19.	_____ is a type of program that is installed with or without your permission or knowledge on your personal computer to collect information about users. It tracks every activity of the user including their browsing habits and sends them to a remote user.
Option A:	Adware
Option B:	Spyware
Option C:	Virus

Option D:	Worm
20.	To protect mobile phones from viruses , one should not
Option A:	Update system and application software
Option B:	Disable Bluetooth, infrared or Wi-Fi when they are not in use
Option C:	Be cautious while opening e-mail and text message attachments and clicking links
Option D:	Join unknown public Wi-Fi networks

Q.2	
A	Solve any Two 5 marks each
i.	Explain cyber defamation.
ii.	Write a note on classification of cybercrime.
iii.	Differentiate between virus and worms.
B	Solve any One 10 marks each
i.	Is your data safe on cloud ? Justify your answer.
ii.	Explain SQL injection attack? State different countermeasures to prevent the attack.
Q.3	
A	Solve any Two 5 marks each
i.	What is intellectual property? What are the different types of intellectual property ?
ii.	Mention the key IT requirements of FISMA.
iii.	Identify the type of E-commerce category for the following websites : A) www.bigbasket.com B) www. IndiaMART.com C) www.Olx.in D) www.Freelancer.com E) https://indianvisaonline.gov.in
B	Solve any One 10 marks each
i.	The way banking operations are conducted has changed tremendously with the development of technology. Explain this statement by discussing various electronic banking services provided by the banks in India.
ii.	What is the Indian Information Technology Act,2000? Explain it's objectives and features?

University of Mumbai
Examination 2021 under cluster ALL (Lead College: VCET)

Examinations Commencing from 15th June 2021

Program: ALL_Institute Level Optional Course 1

Curriculum Scheme: Rev2016

Examination: BE Semester VII

Course Code: ILO 7019 and Course Name: Development Engineering

Time: 2 hour

Max. Marks: 80

Question Number	Correct Option (Enter either 'A' or 'B' or 'C' or 'D')
Q1.	D
Q2.	B
Q3.	A
Q4	D
Q5	B
Q6	A
Q7	A
Q8.	C
Q9.	D
Q10.	D
Q11.	C
Q12.	C
Q13.	B
Q14.	A
Q15.	C
Q16.	C
Q17.	C
Q18.	D
Q19.	C
Q20.	B

University of Mumbai
Examination 2021 under cluster ALL (Lead College: VCET)

Examinations Commencing from 15th June 2021

Program: ALL_Institute Level Optional Course 1

Curriculum Scheme: Rev2016

Examination: BE Semester VII

Course Code: ILO 7019 and Course Name: Development Engineering

Time: 2 hour

Max. Marks: 80

Q1.	Choose the correct option for following questions. All the Questions are compulsory and carry equal marks
1.	Why did Gandhiji advocate decentralization
Option A:	It weakens the state
Option B:	It brings power to the people
Option C:	It is an alternative to Parliamentary democracy
Option D:	All of the above
2.	Which constitutional amendments give recognition and protection to local government
Option A:	64th and 65th
Option B:	73rd and 74th
Option C:	69th and 70th
Option D:	83rd and 84th
3.	Social ethics
Option A:	Defines behaviour of people in society
Option B:	Examines ethics in business environment
Option C:	Are moral principles that guide religion
Option D:	Based on individual's belief of right and wrong
4.	Development Engineering encompasses the following fields
Option A:	Economics
Option B:	Social sciences
Option C:	Engineering
Option D:	All of the above
5.	The term Panchayati Raj signifies (1) urban local self government,(2) rural local self government. Which of the following is true
Option A:	1 only
Option B:	2 only
Option C:	both
Option D:	none
6.	Infant mortality
Option A:	is defined as the annual number of deaths of infant under 1 year old per 1,000 live births.
Option B:	reflects the availability of primary education, the rights of employment and social

	security.
Option C:	is life expectancy up to age 3.
Option D:	reflects the availability of hospitals and childcare facilities, and the parents' wealth.
7.	Which is not a terminology associated with Development Engineering
Option A:	Engineering for Design
Option B:	Engineering for change
Option C:	Humanitarian engineering
Option D:	Engineering for impact
8.	Consider the following statements regarding Human Development Index (HDI): I. The Human Development Index (HDI) is a composite index that measures the average achievements in a country in three basic dimensions of human development. II. The basic dimensions are a long and healthy life, knowledge and a decent standard of living. Which of the following statement(s) is/are correct?
Option A:	Only I
Option B:	Only II
Option C:	Both I, II
Option D:	Neither I,II
9.	To which type of engineers can code of ethics conceived by professional engineering societies be of any use
Option A:	Engineers who are licensed professionals
Option B:	Engineers who belong to professional engineering societies
Option C:	Engineers who are working in Public Sector Enterprise
Option D:	All those people who engage in engineering practice
10.	Which of the following statements is correct regarding 73rd amendment (1) Added eleventh schedule to the constitution (2) Added a new part-IX to the constitution of India, entitled as the Panchayats (3) Gives constitutional status to the PRI (4) Significant landmark in the evolution of grass root democratic institutions in the country
Option A:	1,2,3
Option B:	1,2,4
Option C:	2,3,4
Option D:	1,2,3,4
11.	What are the possible ethical dilemma that a whistleblower can face (1) Public interest vs. private interest (2) Citizenship vs. employment(3) Private benefit vs. employers benefit(4) Short term view vs. Long term view
Option A:	1,2,4
Option B:	1,3,4
Option C:	1,2,3
Option D:	1,4
12.	Which of the following criteria for judging whether proposed research involving human subjects is ethically sound?(1) Risk to subject are minimized (2)Risks are reasonable compared to anticipated benefits (3) Prior informed consent will be

	obtained from subjects (4) Subjects privacy and confidentiality will be maintained. Which of the following is correct?
Option A:	1,2
Option B:	1,3,4
Option C:	1,2,3,4
Option D:	1,3
13.	Which of the following statements are true about values (1) People are always aware of their values (2) Values are the links between needs and action,(3)Moral values are the most fundamental form of values (4) Values are the basis of emotions
Option A:	1,2,3
Option B:	2,3,4
Option C:	1,2,3,4
Option D:	2,4
14.	Panchayati Raj in India was first introduced in 1959 in which state
Option A:	Rajasthan
Option B:	Kerala
Option C:	Tamil Nadu
Option D:	West Bengal
15.	The Human Development Index ranks the countries based on their performance in the key areas of (1) health, (2) sex-ratio, (3)education (4) access to resources
Option A:	1,2,3
Option B:	2,3,4
Option C:	1,3,4
Option D:	1,2,4
16.	Which of the following statements is the most correct description of the relationship between humans and technology
Option A:	Technology impacts upon human action and human beings
Option B:	Human beings" act on, use, make" technology
Option C:	Technology provides apparatus for human action
Option D:	Technology hijacks human autonomy
17.	(1) In Panchayat seats are reserved for SC, ST and women but not for backward classes of citizens (2) Not less than 1/3 of the seats are reserved for women including number of seat reserved for women of SC and ST. Which of these statements is true
Option A:	Only 1
Option B:	Only 2
Option C:	Both
Option D:	none
18.	Which state first reserved 50% seats for women
Option A:	Andhra Pradesh
Option B:	Uttar Pradesh
Option C:	Madhya Pradesh
Option D:	Bihar

19.	Which statement is not correct regarding Gram Sabha
Option A:	It is a body consisting of persons registered in the electoral rolls of a village comprised within the area of the Panchayat level.
Option B:	It is a village assembly consisting of all the registered voters in the area of the Panchayat.
Option C:	Its powers have been determined by the Central Government
Option D:	Its powers and functions at village level are like state legislature at the state level
20.	Which of the following description best describes the principles concerning professional ethics
Option A:	Professional duties must be judged by ethical standards independent of time, place and circumstance
Option B:	Judging professional duties always involves reciprocal adjustment between ends and means
Option C:	Professional duties must by nature be deontological, i.e. the end must not come at the cost of the means
Option D:	Professional duties must be judged only by what they achieve in line with the ends prescribed by the ideals of business

Q2	Solve any Four out of Six	5 marks each
A	As an engineer give your opinion on “Is the use of and development of nuclear power plant ethical?”	
B	Explain the Gandhian philosophy of rural development	
C	List some problems and challenges faced by cooperatives today	
D	Discuss the canons of engineering ethics	
E	Explain the four pillars of Smart city	
F	Corporates become profitable at the cost of ethics. Argue in favour or against the statement and provide examples to justify your arguments	

Q3	Solve any Four out of Six	5 marks each
A	What is the concept of Community development	
B	Give high lights of Balwant Rai Mehta committee report of 1957	
C	Explain the Gandhian philosophy of rural development	
D	Define Ethics, Ethical Dilemma	
E	What are the functions of women cooperatives?	
F	What is a gram sabha and how does it contribute to the development of a village	

University of Mumbai
Examination 2021 under cluster ALL (Lead College: VCET)

Examinations Commencing from 15th June 2021

Program: ALL_Institute Level Optional Course 1

Curriculum Scheme: Rev2016

Examination: BE Semester VII

Course Code: ILO 7017

Course Name: Disaster Management and Mitigation Measures

Time: 2 hour

Max. Marks: 80

Question Number	Correct Option (Enter either 'A' or 'B' or 'C' or 'D')
Q1.	C
Q2.	A
Q3.	B
Q4	A
Q5	D
Q6	A
Q7	A
Q8.	C
Q9.	B
Q10.	A
Q11.	B
Q12.	A
Q13.	B
Q14.	A
Q15.	A
Q16.	B
Q17.	A
Q18.	A
Q19.	A
Q20.	A

University of Mumbai
Examination 2021 under cluster ALL (Lead College: VCET)

Examinations Commencing from 15th June 2021

Program: ALL_Institute Level Optional Course 1

Curriculum Scheme: Rev2016

Examination: BE Semester VII

Course Code: ILO 7017 Course Name: Disaster Management and Mitigation Measures

Time: 2 hour

Max. Marks: 80

Q1.	Choose the correct option for following questions. All the Questions are compulsory and carry equal marks
1.	Hazards can be prioritized by:
Option A:	Manageability, Urgency, Growth, Seriousness
Option B:	Urgency, Manageability, Seriousness, Growth
Option C:	Growth, Manageability, Urgency, Seriousness
Option D:	Seriousness, Manageability, Urgency, Growth
2.	_____ can be defined as threat to life, health, property, and environment.
Option A:	Hazards
Option B:	Vulnerability
Option C:	Disaster
Option D:	Risk
3.	Urbanization usually results in an increase in flood frequency because :
Option A:	Less water can runoff in streams
Option B:	Less water can infiltrate into the ground, so instead is discharged rapidly into streams
Option C:	More water is used by humans and then discharged to streams
Option D:	Rainfall is greater in urban areas than in rural areas
4.	The cycle of disaster consists of the following components:
Option A:	Mitigation, Preparedness, Response, Recovery
Option B:	Preparedness, vulnerability assessment, risk assessment, recovery
Option C:	Mitigation, Risk assessment, Response and Recovery
Option D:	Mitigation, vulnerability assessment, Response and Recovery
5.	Which of the following is not part of geological disaster?
Option A:	Volcanoes
Option B:	Earthquake
Option C:	Tsunami
Option D:	Sea surge
6.	Pandemic disease is defined as:
Option A:	Outbreak of a disease in international scale

Option B:	Outbreak of a disease beyond the area of a disease
Option C:	Congestion in urban areas.
Option D:	Outbreak of a disease in local area
7.	The primary goal of a disaster preparedness plan is:
Option A:	To protect the population
Option B:	To protect valuable resources
Option C:	To keep communications lines open
Option D:	To protect environmental health personnel
8.	Which of the following is not the causes of manmade disaster?
Option A:	Technological
Option B:	Transportation
Option C:	Landslides
Option D:	Production errors
9.	Which of the following coordinate the research activities in different aspects of management at national level?
Option A:	CDM
Option B:	National center for disaster management
Option C:	NICEE
Option D:	Disaster management institute
10.	Various types of funds have been created under which legal frame work
Option A:	Disaster Management Act 2005
Option B:	Disaster Management Act 2006
Option C:	Disaster Management Act 2002
Option D:	National Plan 2008
11.	Which of the following organizations is the apex authority of disaster management in India?
Option A:	NDA
Option B:	NDMA
Option C:	CDMA
Option D:	INDR
12.	The Richter scale expresses an earthquake
Option A:	Magnitude
Option B:	Location
Option C:	Duration
Option D:	Depth
13.	The technique of acquisition of information about an object or phenomenon without being physical contact with the object.
Option A:	Data acquisition
Option B:	Remote Sensing
Option C:	Management system
Option D:	Image processing

14.	What is called for the manuals that identify the role of each officer in State for managing the natural disasters?
Option A:	State Relief Manuals
Option B:	State Environmental Protection Manuals
Option C:	State Disaster Manuals
Option D:	State Protection Manuals
15.	An extreme natural phenomenon capable of causing disaster leading to loss of lives or damage to property is known as-
Option A:	Natural hazard
Option B:	Hazard calculation
Option C:	Desertification
Option D:	Risk
16.	Which of the following sentence about insurance is not true?
Option A:	Insurance guarantees fixed compensation amount prior
Option B:	Insurance market of India is in developed stage, there is no limitations on the cover under insurance for natural disaster.
Option C:	Insurance is limited to major industrial and commercial properties.
Option D:	Role of insurance agencies in disaster management needs to be given more importance.
17.	The National Disaster Management Authority (NDMA) is headed by:
Option A:	Prime Minister of India
Option B:	President of India
Option C:	Governor of States
Option D:	Chief Minister of States
18.	International Tsunami information Center is located in
Option A:	Honolulu
Option B:	Goa
Option C:	Jakarta
Option D:	Puducherry
19.	What is the main role of Government Agencies in Disaster Relief Funding
Option A:	The financial assistance to meet the rescue & relief expenditure during any disaster
Option B:	To build houses in different disasters
Option C:	To advice state government how to manage various disasters
Option D:	To act as common platform for Central & State Government
20.	Who is the Chairperson of NEC, National Executive Committee?
Option A:	Home Secretary
Option B:	Finance Secretary
Option C:	Home Minister
Option D:	Finance Minister

Q2.	Solve any Four out of Six	5 marks each
------------	----------------------------------	---------------------

A	Write a short note on direct and indirect effects of disaster.
B	Describe any 4-natural disaster in brief.
C	Explain objectives of disaster management policy.
D	Write a short note on DM act.
E	Write a short note on role of media in effective disaster management.
F	Explain Community base disaster preparedness.

Q3.	Solve any Four out of Six	5 marks each
A	Define hazards and also brief about modes and causes of hazards.	
B	Explain the role of growing population in frequent occurrences of manmade disasters.	
C	Draw and explain phases of Disaster Management cycle.	
D	Write a short note on advantages of GIS and any one application of GIS in disaster management.	
E	Write a short note on various activities conducted by SDMA.	
F	Explain in detail pre- disaster and post disaster measures.	

University of Mumbai
Examination 2021 under cluster ALL (Lead College: VCET)

Examinations Commencing from 15th June 2021

Program: ALL_Institute Level Optional Course 1

Curriculum Scheme: Rev 2016

Examination: BE Semester VII

Course Code: ILO 7014 and Course Name: Design of Experiments

Time: 2 hour

Max. Marks: 80

Question Number	Correct Option (Enter either 'A' or 'B' or 'C' or 'D')
Q1.	D
Q2.	B
Q3.	A
Q4	B
Q5	A
Q6	A
Q7	B
Q8.	A
Q9.	C
Q10.	C
Q11.	D
Q12.	C
Q13.	B
Q14.	C
Q15.	B
Q16.	D
Q17.	B
Q18.	B
Q19.	A
Q20.	C

University of Mumbai
Examination 2021 under cluster ALL(Lead College: VCET)

Examinations Commencing from 15th June 2021

Program: ALL_Institute Level Optional Course 1

Curriculum Scheme: Rev2016

Examination: BE Semester VII

Course Code: ILO 7014 and Course Name: Design of Experiments

Time: 2 hour

Max. Marks: 80

Q1.	Choose the correct option for following questions. All the Questions are compulsory and carry equal marks
1.	What is FALSE about strategy of experimentation called as best- guess approach _____.
Option A:	Guess dependent solution is produced
Option B:	May take long time
Option C:	Experimenters having knowledge are preferred
Option D:	Experimenters with good guessing power are preferred
2.	Consider the mathematical model $y = f(x, z);$ $\Delta y = \frac{\partial f}{\partial x} \Delta x + \frac{\partial f}{\partial z} \Delta z$ Now determining the optimized x variability so that the variability of y is small is called _____.
Option A:	Process control
Option B:	Process optimization
Option C:	Robust design
Option D:	Process characterization
3.	The analysis procedure used for experimental data with uncontrollable and measurable nuisance factor is _____.
Option A:	Analysis of covariance
Option B:	Blocking
Option C:	Analysis of variance
Option D:	Analysis of average
4.	In the testing for Lack of Fit (LOF) the formula for sum of square for pure error is given by _____.
Option A:	$SS_{PE} = \sum_{i=1}^m \sum_{j=1}^n (\bar{y}_{ij} + \hat{y}_i)^2$
Option B:	$SS_{PE} = \sum_{i=1}^m \sum_{j=1}^n (\bar{y}_{ij} - \hat{y}_i)^2$
Option C:	$SS_{PE} = \frac{1}{2} \sum_{i=1}^m \sum_{j=1}^n (\bar{y}_{ij} - \hat{y}_i)^2$

Option D:	$SS_{PE} = \frac{1}{2} \sum_{i=1}^m \sum_{j=1}^n (\bar{y}_{ij} + \hat{y}_i)^2$
5.	Adding center points to a 2^k factorial design allows the experimenter to obtain an estimate of pure experimental error. This allows the partitioning of the residual sum of squares SSE into two components. Which of the following is correct expression for SSE ?
Option A:	$SS_E = SS_{PE} + SS_{LOF}$
Option B:	$SS_E = SS_{PE} - SS_{LOF}$
Option C:	$SS_E = SS_{PE} * SS_{LOF} / (SS_{PE} + SS_{LOF})$
Option D:	$SS_E = SS_{PE} * SS_{LOF} / (SS_{PE} - SS_{LOF})$
6.	A 2 X 2 factorial _____.
Option A:	is essentially two designs that have been combined into a single study.
Option B:	contains four factors.
Option C:	does not have enough factors to show interactions.
Option D:	is extremely difficult to interpret if interactions are found.
7.	What is the appropriate statistical test for a factorial design?
Option A:	the Modes test
Option B:	ANOVA
Option C:	t-test
Option D:	chi-square
8.	Each main plot is divided into subplots depending on the number of _____.
Option A:	Sub plot treatments
Option B:	Pre plot treatments
Option C:	Post plot treatments
Option D:	Modified plot treatments
9.	In field experiments certain factors may require _____ plots than for others.
Option A:	Lesser
Option B:	Same
Option C:	Larger
Option D:	Small
10.	Factorial designs _____.
Option A:	include no more than one research hypothesis.
Option B:	cannot test participants across more than one condition.

Option C:	contain more than one null hypothesis.
Option D:	are ineffective when matched participants are included.
11.	What type of control chart can be used to plot “number of defectives in the output of a process for making a machine part” data?
Option A:	C
Option B:	U
Option C:	S
Option D:	P
12.	The design in which no main effect is aliased with any other main effect, or with any two-factor interaction, but two-factor interactions are aliased with each other are called _____.
Option A:	Resolution VI design
Option B:	Resolution V design
Option C:	Resolution IV design
Option D:	Resolution III design
13.	Which of the following would be a useful contributor to a strategy of mass customization?
Option A:	Economics of scale
Option B:	Modular Design
Option C:	Offshoring
Option D:	Fixed Automation
14.	Which of the following is true?
Option A:	Having more than one dependent variable allows the examination of interactions between them.
Option B:	There must be the same number of independent variables as there are dependent variables.
Option C:	An experiment can have more than one dependent variable.
Option D:	An experiment can only have one dependent variable.
15.	Small differences in results from trial to trial can happen in case of _____.
Option A:	good data sets
Option B:	bad data sets
Option C:	sample data sets
Option D:	attribute data sets
16.	Which of the followings is true about sample size?
Option A:	the sample size should be as small as possible
Option B:	the sample size can be random
Option C:	the sample size is insignificant
Option D:	depends upon the quality characteristic under evaluation i.e. Variable or attribute
17.	Which of the following is an example of attribute data?
Option A:	volume
Option B:	switch on & switch off
Option C:	Temperature
Option D:	pressure

18.	A method for quantitatively identifying the right inputs and parameter levels for making a high quality product or service is called as -
Option A:	regression analysis
Option B:	design of experiments
Option C:	random factor design
Option D:	split plot design
19.	2^3 indicates how many levels?
Option A:	2
Option B:	3
Option C:	4
Option D:	8
20.	Larger the better S/N ratio is chosen in case of -
Option A:	undesirable characteristics
Option B:	bad characteristics
Option C:	desirable characteristics
Option D:	good characteristics

Q2. (20 Marks)	Solve any Four out of Six	5 marks each
A	What are Experimental Designs? Give its applications.	
B	What are guidelines for designing experiments?	
C	Write short note on S/N ratios.	
D	What are Good and Bad datasets?	
E	What is RMS?	
F	Explain Construction of Normal Probability Plot.	

Q3. (20 Marks)	Solve any Two Questions out of Three	10 marks each
A	What do you understand from the term 2^k design? Explain with an example.	
B	Discuss testing for lack of fit	
C	What are statistical aspects of conducting tests?	

University of Mumbai

Examination 2020 under cluster 04(Lead College:Pillai College of Engineering)

Examinations Commencing from 15th June 2021 to 26th June 2021

Program: B.E. Computer

Curriculum Scheme: Rev 2016

Examination: BE Semester: VII

Course Code: CSC701 and Course Name: Digital Signal & Image Processing

Time: 2 hour

Max. Marks: 80

Q1. Choose the correct option for following questions. All the Questions are compulsory and carry equal marks

Question Number	Correct Option (Enter either 'A' or 'B' or 'C' or 'D')
Q1.	B
Q2.	D
Q3.	C
Q4	A
Q5	A
Q6	B
Q7	D
Q8.	C
Q9.	C
Q10.	D

Q11.	D
Q12.	C
Q13.	C
Q14.	D
Q15.	A
Q16.	B
Q17.	B
Q18.	C
Q19.	A
Q20.	B

Q2. (total-20 Marks)

Model Answer: (with marks distribution)

Q2.	Solve any Four out of Six. (5 marks each)
A	Define: 1) Symmetric(Even) and Antisymmetric (Odd) signals 2)Energy and power signals with the help of examples Each signal carries 2.5 Marks
Ans	1) Symmetric(Even) and Antisymmetric (Odd) signals

The discrete time signal may exhibit symmetry or antisymmetry nature with respect to $n=0$.

Even Signal (Symmetric): There is symmetry with respect $n=0$. $x(n) = x(-n)$

Odd Signal (Antisymmetric): There is antisymmetry with respect $n=0$. $x(n) = -x(-n)$

$$x(n) = \{1, -2, 3, -2, 1\}$$

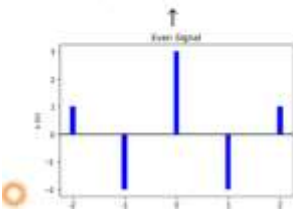

$$x(n) = \{1, -2, 3, 2, -1\}$$

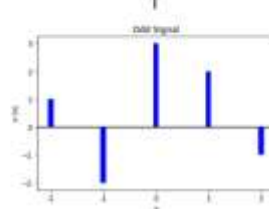

2) Energy and power signals

The energy E of a discrete time signal $x(n)$ is defined as,

$$E = \sum_{-\infty}^{\infty} |x(n)|^2$$

The energy of a signal may be finite or infinite, and can be applied to complex valued and real valued signals.

If energy E of a discrete time signal is finite and nonzero, then the discrete time signal is called an **energy signal**. The exponential signals are examples of energy signals.

The average power of a discrete time signal $x(n)$ is defined as,

$$P = \lim_{N \rightarrow \infty} \frac{1}{2N+1} \sum_{-N}^N |u(n)|^2$$

If power P of a discrete time signal is finite and nonzero, then the discrete time signal is called a power signal. The periodic signals are examples of power signals.

For energy signals, the energy will be finite and average power will be zero. For power signals the average power is finite and energy will be infinite.

For energy signal, $0 < E < \infty$ and $P = 0$

For power signal, $0 < P < \infty$ and $E = \infty$

B

Compute linear convolution of the causal sequence $x(n) = \{4, 5, 6, 1, 1, 2, 3\}$, $h(n) = \{1, -1\}$ using Overlap Add Method.

Ans

SET2 Q.2 B
 Compute linear convolution of the causal sequence
 $x(n) = \{4, 5, 6, 1, 1, 2, 3\}$ and $h(n) = \{1, -1\}$
 using Overlap Add Method.

$S = 2$
 $L > = 5$
 $L = 2$

$M = 1 + 5 - 1$
 $M = 2 + 2 - 1$
 $M = 3$

$h(n) = \{1, -1, 0\}$ One zero added.

$$\begin{bmatrix} 1 & 0 & -1 \\ -1 & 1 & 0 \\ 0 & -1 & 1 \end{bmatrix} \times \begin{bmatrix} 4 \\ 5 \\ 0 \end{bmatrix} \begin{bmatrix} 6 \\ 1 \\ 0 \end{bmatrix} \begin{bmatrix} 1 \\ 2 \\ 0 \end{bmatrix} \begin{bmatrix} 3 \\ 0 \\ 0 \end{bmatrix}$$
 extra zero

$$\begin{array}{cccccccc} 4 & 1 & -5 & & & & & \\ & 6 & -5 & -1 & & & & \\ & & & 1 & 1 & -2 & & \\ & & & & & 3 & -3 & 0 \end{array}$$

$$4 \quad 1 \quad 1 \quad -5 \quad 0 \quad 1 \quad 1 \quad -3 \quad 0$$
 extra zero

c

Sketch the following discrete time signal

$$x(n) = 3 \quad 1 \quad 5 \quad 4 \quad 2 \quad 3$$

\uparrow

Plot the signals

- i) $x(n-1)$ ii) $x(-n) u(n)$ iii) $x(n-1) u(-n-1)$

Ans	
-----	--

D	<p>Perform circular convolution on two given sequence $x_1(n)$ and $x_2(n)$. Use Graphical Method only. Both signal starts from 0.</p> <p>$x_1(n) = \{1, 2, -1, 1\}$ $x_2(n) = \{2, 4, 6, 8\}$</p>
---	---

Ans	
-----	--

E	<p>Derive FFT flow graph for $N=4$. Hence find DFT of $x(n) = \{4, 3, 2, 2\}$</p>
---	---

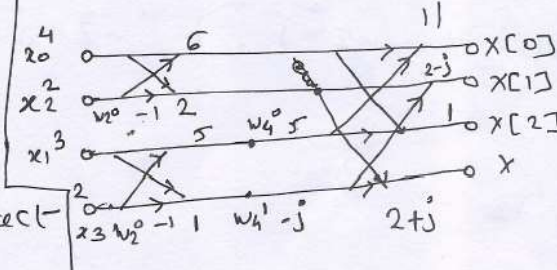
<p>Ans</p>	<p>③ $x(n) = \{4, 3, 2, 2\}$</p> <p>$x_0 \ x_1 \ x_2 \ x_3$ $x_0 \ x_2 \ x_1 \ x_3$ $4 \ 2 \ 3 \ 2$</p> <p>$2^0 - 1 \quad 1$ Add, 1 subtract</p> <p>$4 + W_2^0(2) = 6$ $4 - W_2^0(2) = 2$</p> <p>$3 + W_2^0(2) = 5$ $3 - W_2^0(2) = 1$</p> <p>6 2 5 1</p> <p>$2^1 = 2 \quad 2$ Add 2 subtract</p> <p>6 2 5 1 $6 + W_4^0(5) = 11$ $2 + W_4^1(1) = 2 + (-j) = 2-j$</p> <hr/> <p>$6 - W_4^0(5) = 1$ $2 - W_4^1(1) = 2 - (-j) = 2+j$</p> <p>11, $2-j$, 1, $2+j$</p> 
<p>F</p>	<p>Explain any three properties of DFT</p>
<p>Ans</p>	<p>Each property 1Mark</p>

Q3. (total-20 Marks)

Model Answer: (with marks distribution)

<p>Q3.</p>	<p>Solve any Four out of Six. (5 marks each)</p>
<p>A</p>	<p>What happens when spatial and gray level resolution of a digital image is decreases? Decreasing Spatial resolution:2.5 Marks Decreasing gray level resolution:2.5 Marks</p>
	<p>Subsampling (Effect of reducing the spatial resolution)</p> <p>Decreasing spatial resolution of a digital image, within the same area, result in Checkerboard Pattern. Also image details are lost when the spatial resolution is reduced.</p> <p>The sub-sampling process means deleting the appropriate number of rows and columns from the original image.</p> <p>Gray Level Resolution</p> <p>Gray-level resolution refers to the smallest discernible change in gray level. Gray level resolution is equal to the number of bits per pixel. It is determined by the quantization process. The number of gray levels is usually an integer power of 2.</p> <p>Effect of reducing the gray level resolution</p>

	Decreasing the gray-level resolution of a digital image may result in false contouring. This effect is caused by the use of an insufficient number of gray levels in smooth areas of a digital image.																
B	Explain characteristic features of BMP, TIFF file format BMP: 2.5 Marks TIFF:2.5 Marks																
	<p>BMP</p> <table border="1"> <tr> <td>Type</td> <td>Bitmap</td> </tr> <tr> <td>Colors</td> <td>1-, 4-, 8-, 16-, 24-, and 32-bits</td> </tr> <tr> <td>Compression</td> <td>RLE, uncompressed</td> </tr> <tr> <td>Maximum Image Size</td> <td>32Kx32K and 2Gx2G pixels</td> </tr> <tr> <td>Multiple Images Per File</td> <td>No</td> </tr> <tr> <td>Numerical Format</td> <td>Little-endian</td> </tr> <tr> <td>Originator</td> <td>Microsoft Corporation</td> </tr> <tr> <td>Platform</td> <td>Intel machines running Microsoft Windows, Windows NT, Windows 95, OS/2, and MS-DOS</td> </tr> </table> <p>Advantages:</p> <ul style="list-style-type: none"> • Bitmap files support all versions of Windows. • Most suitable for icons and small images. • Medium quality images are produced. <p>Disadvantages:</p> <ul style="list-style-type: none"> • It has the largest file size compared to other formats. • We tend to lose the quality of the picture obtained. <p>TIFF</p> <p>Features:</p> <ul style="list-style-type: none"> • Portability (works under MS-DOS, Unix, Mac) • Scalable color depth from 1-bit (b/w) to 24-bit (true color) • Numerous compression schemes: Uncompressed, RLE, LZW (GIF), CCITT Group 3&4 Fax, JPEG, PackBit 	Type	Bitmap	Colors	1-, 4-, 8-, 16-, 24-, and 32-bits	Compression	RLE, uncompressed	Maximum Image Size	32Kx32K and 2Gx2G pixels	Multiple Images Per File	No	Numerical Format	Little-endian	Originator	Microsoft Corporation	Platform	Intel machines running Microsoft Windows, Windows NT, Windows 95, OS/2, and MS-DOS
Type	Bitmap																
Colors	1-, 4-, 8-, 16-, 24-, and 32-bits																
Compression	RLE, uncompressed																
Maximum Image Size	32Kx32K and 2Gx2G pixels																
Multiple Images Per File	No																
Numerical Format	Little-endian																
Originator	Microsoft Corporation																
Platform	Intel machines running Microsoft Windows, Windows NT, Windows 95, OS/2, and MS-DOS																

	<ul style="list-style-type: none"> • Max file size of 4096 MB • Multiple images per file • Extensibility for future <p>Advantages:</p> <ul style="list-style-type: none"> • Widely supported, especially between Macintosh computers and Windows-based computers • Optional compression • Extensible format allows for many optional features <p>Disadvantages:</p> <ul style="list-style-type: none"> • Not supported by Web browsers • Extensibility results in many different types of TIFF pictures. • Not all TIFF files are compatible with all programs that support the baseline TIFF standard <p>Advantages</p> <ul style="list-style-type: none"> • Superior compression for photographic or realistic artwork • Variable compression allows file size control • Interlacing (for Progressive JPEG files) • Widely supported Internet standard <p>Disadvantages</p> <ul style="list-style-type: none"> • Lossy compression degrades original picture data. • When you edit and resave JPEG files, JPEG compounds the degradation of the original picture data; this degradation is cumulative. • JPEG is not suitable for simpler pictures that contain few colors, broad areas of similar color, or stark differences in brightness.
C	<p>Why point processing operations are called zero memory point operations? Are they subjective or objective. Explain with the reason.</p> <p>Reason for zero memory point operations: 2.5 Marks</p> <p>Reason for subjective/objective: 2.5 Marks</p>
Ans	<p>It is called zero memory operations as each output only depend on the input intensity at the point. It is called point processing as operations modify individual pixel is true.</p> <p>Enhancement is used to enhance quality of image by changing contrast, brightness,</p>

dynamic range etc. depending on user choice or application requirement.
 Enhancement operation is controlled by user. There is no any mathematical way to start and stop operations.
 Enhancement changes only external appearance of the image by changing individual pixel, or pixel by using neighbouring information.
 It does not add any new visual information in an image.

D Perform Histogram Equalization on a given data. Draw histogram of orginal and equalized histogram.

Gray Level	0	1	2	3	4	5	6	7
No. of Pixels	790	1023	850	656	329	245	122	81

Transformation table 3 Marks, 2 Marks or Original and equalized Histogram

Ans

Gray Level	n_k	$p_k = n_k/n$	CDF	CDFx(L-1)	Round Off
0	790	0.19	0.19	1.33	1
1	1023	0.25	0.44	3.08	3
2	850	0.21	0.65	4.55	5
3	656	0.16	0.81	5.67	6
4	329	0.08	0.89	6.23	6
5	245	0.06	0.95	6.65	7
6	122	0.03	0.98	6.86	7
7	81	0.02	1.00	7.00	7
n=	4096				

Gray level	No. Of Pixels
0	0
1	790
2	0
3	1023
4	0
5	850
6	656+329=985
7	245+122+81=448

E For given 3 bits per pixel , 4x4 size image perform following operations.
 i) Thresholding T=3
 ii) Intensity level slicing with background r1= 3 & r2= 5
 iii) Bit plane slicing for MSB and LSB plan
 iv) Digital negative

3	3	1	2
1	4	0	7
3	4	2	6
2	4	6	4

For i) 1 Mark ii) 1 Mark iii) 2 Mark iv) 1 Mark

Ans

Threshold T=3 Negative Intensity level slicing Bit plane slicing (MSB & LSB)

0	0	0	0
0	7	0	7
0	7	0	7
0	7	7	7

4	4	6	5
6	3	7	0
4	3	5	1
5	3	1	3

7	7	1	2
1	7	0	7
7	7	2	6
2	7	6	7

0	0	0	0
0	1	0	1
0	1	0	1
0	1	1	1

1	1	1	0
1	0	0	1
1	0	0	0
0	0	0	0

F	<p>Define segmentation. Explain Image Segmentation based on Discontinuities in detail?</p> <p>Segmentation refers to another step in image processing methods where input are images and outputs are attributes extracted from images.</p> <p>It subdivides an image into its constituent regions or objects.</p> <p>The level to which the subdivision is carried depends on the problem being solved. That is, segmentation should stop when the objects of interest in an application have been isolated.</p> <p>e.g. automated inspection of electronic assemblies;</p> <p>Segmentation algorithms are based on 1 of 2 basic properties of intensity values: discontinuity & similarity.</p> <p>Discontinuity: Approach is to partition image based on abrupt changes in intensities (edges). e.g. point, line, edge</p> <p>Similarity: Approach is to partition the image based on similar regions according to predefined criteria. e.g. thresholding, region growing, region splitting & merging</p> <p>Detection of Discontinuities</p> <p>There are 3 basic types of discontinuities in digital images:</p> <p>1. Point 2. Line 3. Edges</p>

University of Mumbai

Examination 2020 under cluster 4 (Lead College: Pillai College of Engineering)

Examinations Commencing from 15th June 2021 to 26th June 2021

Program: B.E. Computer

Curriculum Scheme: Rev 2016

Examination: BE Semester: VII

Course Code: CSC701 and Course Name: Digital Signal & Image Processing

Time: 2 hour

Max. Marks: 80

Q1.	Choose the correct option for following questions. All the Questions are compulsory and carry equal marks
1.	Determine the given system is $y(n) = x(n) $
Option A:	Linear
Option B:	Non linear
Option C:	Can't Predict
Option D:	Data insufficient
2.	Determine the signal is $y(n) = \sin(2n + 1)x(n) + \sin(n)x(2n + 1)$
Option A:	Can't predict
Option B:	Depends on sin function
Option C:	Static
Option D:	Dynamic
3.	Find energy for the given signal. $x(n) = u(n) - u(n - 7)$
Option A:	49
Option B:	0
Option C:	7
Option D:	∞
4.	For a given signal $x(n) = 1 \quad 3 \quad 7 \quad 9$ <p style="text-align: center;"> ↑</p> Determine the range and total number of terms in Autocorrelation
Option A:	-3 to 3, 7
Option B:	-1 to 5, 7
Option C:	-2 to 4, 7
Option D:	-3 to 3, 8

5.	Find stability criteria $h(n) = (5)^n u(-n)$
Option A:	Stable, $h(n)=1.25$
Option B:	Unstable, $h(n)=1.25$
Option C:	Unstable, ∞
Option D:	Stable, 0
6.	Obtain Autocorrelation of the given signal $x(n) = \begin{matrix} 4 & 3 & 2 \\ & & \uparrow \end{matrix}$
Option A:	$\begin{matrix} 8 & 18 & 29 & 18 & 8 \\ & & & \uparrow & \end{matrix}$
Option B:	$\begin{matrix} 8 & 18 & 29 & 18 & 8 \\ & & \uparrow & & \end{matrix}$
Option C:	$\begin{matrix} 29 & 18 & 8 & 18 & 8 \\ & & & \uparrow & \end{matrix}$
Option D:	$\begin{matrix} 29 & 8 & 18 & 8 & 18 \\ & & & \uparrow & \end{matrix}$
7.	Which of the following statement is true for FFT & DFT
Option A:	FFT is time domain and DFT is frequency domain.
Option B:	Results of FFT and DFT are same in magnitude but phase is different.
Option C:	Results of FFT and DFT are same in phase but different in magnitude.
Option D:	Results of FFT and DFT are same, FFT is more efficient than DFT.
8.	DTFT of a impulse signal is
Option A:	∞
Option B:	0
Option C:	1
Option D:	-1
9.	Let $x(n)=\{ 0,1,2,3,2,3,5,3\}$ With 8 Point DFT, evaluate $X[0]$ & $X[4]$ without computing DFT.
Option A:	$X[0]= 19, X[4]=0$
Option B:	$X[0]= 0, X[4]=19$
Option C:	$X[0]= 19, X[4]=-1$

Option D:	X[0]= -1, X[4]=19
10.	For a given analog signal $x(t) = 2\sin(480\pi t) + 3\sin(120\pi t)$ What is the minimum sampling rate to avoid aliasing
Option A:	240Hz
Option B:	60Hz
Option C:	300Hz
Option D:	480Hz
11.	Determine X[0] & X[2] For five point DFT $X[k]=\{15, ?, -2.5+0.81j, ?, -2.5-3.44j\}$ Determine X[1] & X[3]
Option A:	X[1]= -2.5-3.44j X[3]= -2.5+0.81j
Option B:	X[1] = X[3]=-2.5+0.81j
Option C:	X[1] = X[3] = -2.5+3.44j
Option D:	X[1]= -2.5+3.44j X[3]= -2.5-0.81j
12.	Which file format uses DCT as a main method
Option A:	BMP
Option B:	TIFF
Option C:	JPEG
Option D:	PDF
13.	Decreasing spatial resolution of a digital image within the same area results in
Option A:	Log transformation
Option B:	False contouring
Option C:	Checkerboard Pattern
Option D:	Power law transformation
14.	In contrast stretching, is it possible to i) make darker portion more darker ii) make darker portion brighter
Option A:	Yes, No
Option B:	No, Yes

Option C:	No, No
Option D:	Yes, Yes
15.	Which operator is used to expand low value pixels and compresses high value pixels.
Option A:	Log
Option B:	Exponential
Option C:	Slope
Option D:	CDF
16.	In the digital image of M rows and N columns and L discrete gray levels, calculate the bits required to store a digitized image for M=N=8 and L=4.
Option A:	64
Option B:	128
Option C:	32
Option D:	16
17.	Can we generate image from its histogram.
Option A:	Yes
Option B:	No
Option C:	Depends on tonal resolution
Option D:	Depends on gray level resolution
18.	What happen if max filter is used instead of median filter to remove salt & pepper noise.
Option A:	Enhance pepper noise
Option B:	Remove gaussian if exist
Option C:	Enhance salt noise
Option D:	Same effect as median filter
19.	The edges and other abrupt changes in gray-level of an image are associated with
Option A:	High frequency components
Option B:	Low frequency components
Option C:	Edges with high frequency and other abrupt changes in gray-level with low frequency components
Option D:	Edges with low frequency and other abrupt changes in gray-level with high frequency components
20.	Does Sobel & Prewitt edge detection operators performs smoothing while

	extracting edges.
Option A:	No
Option B:	Yes
Option C:	Depends on image resolution
Option D:	Depends on gray level

Subjective:

Q2.	Solve any Four out of Six. (5 marks each)
A	Define: 1) Symmetric(Even) and Antisymmetric (Odd) signals 2)Energy and power signals with the help of examples.
B	Compute linear convolution of the causal sequence $x(n)=\{4,5,6,1,1,2,3\}$, $h(n)=\{1,-1\}$ using Overlap Add Method.
C	<p>Sketch the following discrete time signal</p> $x(n) = 3 \quad 1 \quad 5 \quad 4 \quad 2 \quad 3$ <p style="text-align: center;">↑</p> <p>Plot the signals</p> <p>i) $x(n-1)$ ii) $x(-n) u(n)$ iii) $x(n-1) u(-n-1)$</p>
D	Perform circular convolution on two given sequence $x1(n)$ and $x2(n)$. Use Graphical Method only. Both signal starts from 0. $x1(n)=\{1, 2, -1, 1\}$ $x2(n)=\{2, 4, 6, 8\}$
E	Derive FFT flow graph for $N=4$. Hence find DFT of $x(n)=\{4, 3, 2, 2\}$
F	Explain any three properties of DFT

Q3.	Solve any Four out of Six. (5 marks each)
A	What happens when spatial and gray level resolution of a digital image is decreases?
B	Explain characteristic features of BMP, TIFF file format.
C	Why point processing operations are called zero memory point operations? Are they subjective or objective. Explain with the reason.
D	Perform Histogram Equalization on a given data. Draw histogram of original and

	equalized histogram.																		
	<table border="1"> <tr> <td>Gray Level</td> <td>0</td> <td>1</td> <td>2</td> <td>3</td> <td>4</td> <td>5</td> <td>6</td> <td>7</td> </tr> <tr> <td>No. of Pixels</td> <td>790</td> <td>1023</td> <td>850</td> <td>656</td> <td>329</td> <td>245</td> <td>122</td> <td>81</td> </tr> </table>	Gray Level	0	1	2	3	4	5	6	7	No. of Pixels	790	1023	850	656	329	245	122	81
Gray Level	0	1	2	3	4	5	6	7											
No. of Pixels	790	1023	850	656	329	245	122	81											
E	<p>For given 3 bits per pixel , 4×4 size image perform following operations.</p> <p>i) Thresholding $T=3$</p> <p>ii) Intensity level slicing with background $r_1= 3$ & $r_2= 5$</p> <p>iii) Bit plane slicing for MSB and LSB plan</p> <p>iv) Digital negative</p> <table border="1" style="margin-left: auto; margin-right: auto;"> <tr> <td>3</td> <td>3</td> <td>1</td> <td>2</td> </tr> <tr> <td>1</td> <td>4</td> <td>0</td> <td>7</td> </tr> <tr> <td>3</td> <td>4</td> <td>2</td> <td>6</td> </tr> <tr> <td>2</td> <td>4</td> <td>6</td> <td>4</td> </tr> </table>	3	3	1	2	1	4	0	7	3	4	2	6	2	4	6	4		
3	3	1	2																
1	4	0	7																
3	4	2	6																
2	4	6	4																
F	Define segmentation. Explain Image Segmentation based on Discontinuities in detail?																		

University of Mumbai
Examination 2021 under cluster ALL (Lead College: VCET)

Examinations Commencing from 15th June 2021

Program: ALL_Institute Level Optional Course 1

Curriculum Scheme: Rev2016

Examination: BE Semester VII

Course Code: ILO 7018 and Course Name: EAM

Time: 2 hour

Max. Marks: 80

Question Number	Correct Option (Enter either 'A' or 'B' or 'C' or 'D')
Q1.	A
Q2.	C
Q3.	D
Q4	C
Q5	B
Q6	B
Q7	C
Q8.	C
Q9.	C
Q10.	B
Q11.	B
Q12.	D
Q13.	D
Q14.	D
Q15.	D
Q16.	B
Q17.	C
Q18.	D
Q19.	B
Q20.	B

University of Mumbai
Examination 2021 under cluster ALL (Lead College: VCET)

Examinations Commencing from 15th June 2021

Program: **ALL_Institute Level Optional Course 1**

Curriculum Scheme: Rev2016

Examination: BE Semester VII

Course Code: ILO 7018 and Course Name: EAM

Time: 2 hour

Max. Marks: 80

Q1.	Choose the correct option for following questions. All the Questions are compulsory and carry equal marks
1.	Choose an incorrect form of natural gas as energy source.
Option A:	Nitrogen
Option B:	LPG
Option C:	LNG
Option D:	CNG
2.	Which of the following power generation type have very least share in India's total installed capacity? (Ref. year Feb2014)
Option A:	Thermal
Option B:	Hydro-electric
Option C:	Nuclear
Option D:	Renewable
3.	In which sector the energy consumption is highest in India?
Option A:	Agriculture
Option B:	Transport
Option C:	Residential
Option D:	Industry
4.	The energy management aims at producing goods and provide services with
Option A:	only the least environmental effect
Option B:	Only the least cost
Option C:	least cost and least environmental effect
Option D:	either least cost or least environmental effect
5.	The type of Energy Audit to be performed depends on:
Option A:	Cost of energy
Option B:	Depth to which final audit is needed
Option C:	The type of Fuel used in Industries
Option D:	Manpower in an Industry
6.	Understanding energy cost is important factor for :
Option A:	Improving system Efficiency
Option B:	Awareness creation and Saving calculation
Option C:	For manpower calculation
Option D:	For material procurement

7.	Penalties were imposed in HT Electricity bills before 1st April 2020 due to:
Option A:	Crossing Maximum Demand
Option B:	Not maintaining Power Factor above specified value
Option C:	Both for crossing maximum demand and non-maintaining power factor above specified value
Option D:	Not maintaining the duration of Electricity use
8.	Plant energy performance (PEP) is the measure of:
Option A:	Material getting used in an Industry
Option B:	Manpower utilization in an Industry
Option C:	How well the energy management programme is doing
Option D:	Utilization of resources available
9.	A utility bill shows an average pf of 0.72 with average KW of 627.How much KVAR is required to improve pf to 0.95
Option A:	425KVAR
Option B:	336 KVAR
Option C:	398 KVAR
Option D:	192 KVAR
10.	Capacitors with automatic power factor controller when installed in a plant:
Option A:	Reduces the voltage of the plant
Option B:	Reduces the reactive power drawn from grid
Option C:	Reduces active power drawn from grid
Option D:	Increases the load current of the plant
11.	The following function cannot be achieved with automatic power factor controllers.
Option A:	KVAR control
Option B:	kW control
Option C:	PF control
Option D:	Voltage control
12.	The material used for core of Energy efficient transformer is
Option A:	Cold Rolled Grain Oriented Steel
Option B:	Silicon alloyed iron(grain oriented)
Option C:	Copper
Option D:	Amorphous core - metallic glass alloy
13.	The characteristic of conventional ballast in lighting application is one among the following:
Option A:	They have low operational losses than electronic ballasts
Option B:	They do not require a mechanical switch (starter)
Option C:	They have tuned circuit to deliver power at very high frequency
Option D:	They have high operational losses and high temperature rise
14.	Following is NOT the property of Soft starter
Option A:	less Mechanical stress
Option B:	Improved Power factor
Option C:	Lower maximum demand
Option D:	High Mechanical stress

15.	Length of interior, Width of interior and the mounting height are required to calculate..
Option A:	Lux level
Option B:	Colour Rendering Index
Option C:	Power in watts
Option D:	Room Index
16.	Which of the following lamps has the maximum lamp efficiency in lumens/Watt?
Option A:	Metal Halide
Option B:	HPSV
Option C:	Incandescent
Option D:	Fluorescent
17.	Slip method for measurement of motor loading has disadvantage of
Option A:	High cost
Option B:	Large time required
Option C:	Less accuracy
Option D:	More calculations
18.	Which of the following produces energy because of temperature difference at various levels in ocean
Option A:	Tidal energy
Option B:	Wave energy
Option C:	Solar energy
Option D:	Ocean thermal energy
19.	What percentage of the sun's energy falling on a silicon solar panel gets converted into electricity?
Option A:	Around 35
Option B:	Around 15
Option C:	Around 75
Option D:	Around 50
20.	Identify the type of steam if it floats out intermittently in a whitish cloud
Option A:	Leaking steam
Option B:	Flash steam
Option C:	Cloud steam
Option D:	Superheated Steam

Q2	
A	Solve any Two 5 marks each
i.	Explain any five features of Energy Conservation Act 2001
ii.	Define monitoring and targeting. Explains elements of M & T system.
iii.	Explain demand charges and TOD tariff.
B	Solve any One 10 marks each
i.	Explain general fuel economy measures in boilers.
ii.	A 415 V, 20kW, 3-ph, 50Hz Induction motor operates at full load, with

	86% efficiency and 0.85 power factor lagging: a) Find the current drawn by the motor b) If this motor is replaced by 92% energy efficient motor of same capacity with 0.88 power factor, what will be the power savings in terms of kW. If annual working hours of that motor are 7000 and rate of electricity is Rs.10 per Kwh, find annual energy saving.																		
Q3																			
A	Solve any Two 5 marks each																		
i.	List any Five Energy Conservation opportunities in lighting system																		
ii.	Explain step by step approach of electrical load management.																		
iii.	What are the advantages of green buildings and state 3 examples of green buildings in India?																		
B	Solve any One 10 marks each																		
i.	Explain energy saving opportunities in steam distribution systems.																		
ii.	Find ILER for the industrial illumination system where colour rendering is not essential. Average lux level measured 500lux. Room dimensions 9m*4m*4m. Fixtures are suspended from ceiling at 0.5m. Height of work plane is 0.8m. There are 10 tube lights of 52W each in the room. Suggest the measure if required and find annual wastage if any, If lamps are used for 8 hours a day and 300 days in a year. The room index and associate target lux/W/m ² for the mentioned system is as follows <table border="1" style="margin-left: auto; margin-right: auto;"> <thead> <tr> <th>Room Index</th> <th>Target lux/W/m²</th> </tr> </thead> <tbody> <tr><td>1</td><td>52</td></tr> <tr><td>1.25</td><td>55</td></tr> <tr><td>1.5</td><td>58</td></tr> <tr><td>2</td><td>61</td></tr> <tr><td>2.5</td><td>64</td></tr> <tr><td>3</td><td>65</td></tr> <tr><td>4</td><td>66</td></tr> <tr><td>5</td><td>67</td></tr> </tbody> </table>	Room Index	Target lux/W/m ²	1	52	1.25	55	1.5	58	2	61	2.5	64	3	65	4	66	5	67
Room Index	Target lux/W/m ²																		
1	52																		
1.25	55																		
1.5	58																		
2	61																		
2.5	64																		
3	65																		
4	66																		
5	67																		

University of Mumbai
Examination 2020 under cluster_4 (Lead College: PCE, New Panvel)
Examinations Commencing from 15th June 2021 to 26th June2021

Program: **Computer Engineering**

Curriculum Scheme: Rev2016

Examination: BE Semester VII

Course Code: CSC702 and Course Name: Mobile Communication & Computing

Time: 2 hour

Max. Marks: 80

Q1. Choose the correct option for following questions. All the Questions are compulsory and carry equal marks **40 marks (2 marks each)**

Question Number	Correct Option
Q1.	C
Q2.	C
Q3.	B
Q4	A
Q5	C
Q6	D
Q7	D
Q8.	C
Q9.	B
Q10.	C

Q11.	A
Q12.	C
Q13.	D
Q14.	C
Q15.	D
Q16.	A
Q17.	B
Q18.	A
Q19.	B
Q20.	A

Q2. Model Answer: (with marks distribution)

A. Explain how to calculate nearest co- channel cell in cellular system

$N = i^2 + ij + j^2$ -formula 1 mark

Explain the procedure using this formula – 4 marks

B. List out some advantages of Mobile Computing.

(For each advantage -1 mark)

Location Flexibility - This has enabled users to work from anywhere as long as there is a connection established.

Increase in Productivity- Mobile devices can be used out in the field of various companies, therefore reducing the time and cost for clients and themselves.

Entertainment- Mobile devices can be used for entertainment purposes, for personal and even for presentations to people and clients.

Portability- this would be one of the main advantages of mobile computing, you are not restricted to one location in order for you to get jobs done or even access email on the go

Cloud Computing- This service is available for saving documents on a online server and being able to access them anytime and anywhere when you have a connection to the internet and can access these files on several mobile devices or even PCs at home.

C. Why the traditional IP cannot be used in a mobile network. What are the main differences between the traditional IP and the mobile IP?

IP is responsible for routing a packet to any host, connected to the Internet, uniquely identified by an assigned IP address. The nodes in the LAN are assigned an address based on the LAN address.

In the traditional IP addressing scheme, when a host moves to a different location, it may move to another network. As a result, it needs to change its IP address. – 3 marks

The mobile IP allows mobile computers to stay connected to the Internet regardless of their location and without changing their IP address.

The traditional IP does not support user mobility. Mobile IP was created by extending IP to enable users to keep the same IP address while travelling to a different network. – 2 marks

D. Difference between LTE and LTE-Advanced.

Ans. For each difference 1 mark. Total 5 differences - 5 marks

E. What are the functions of MSC in GSM architecture?

(5 functionalities - 5 marks)

MSCs are high-performance digital ISDN switches. They set up connections to other MSCs and to the BSCs via the A interface, and form the fixed backbone network of a GSM system. Typically, an MSC manages several BSCs in a geographical region. A gateway MSC (GMSC) has additional connections to other fixed networks, such as PSTN and ISDN.

F. Why is physical layer in IEEE802.11 subdivided ? What are its sublayers?

The physical layer in IEEE802.11 is subdivided because a sublayer has to be dependant on the upper layers (architecture dependant) and the other has to be medium dependant. The two sublayers are namely, - 1 Mark

*Physical layer convergence protocol – explanation - 2 Mark

* Physical medium dependant sublayer - explanation – 2 Mark

Q3. Model Answer: (with marks distribution)

A. Discuss the architecture of UMTS?

What is UMTS- 1 mark

Components of UMTS – 1 mark

Diagram – 2 marks

Interfaces – 2 marks

Explanation and functionality of each component- 4 marks

B. What is triangular routing problem? How do you solve it?

Triangular routing problem explanation -5 marks

Solution – 5 marks

C. What is the need of Cellular IP? Explain Cellular architecture with paging.

Need of Cellular IP – 4 marks

Cellular IP explanation – 3 marks

Paging – 3 marks

University of Mumbai
Examination 2020 under cluster 4 (Lead College: PCE, New Panvel)
Examinations Commencing from 15th June 2021 to 26th June2021

Program: **Computer Engineering**

Curriculum Scheme: Rev2016

Examination: FE/SE/TE/BE Semester VII

Course Code: CSC702 and Course Name: Mobile Communication & Computing

Time: 2 hour

Max. Marks: 80

Q1.	Choose the correct option for following questions. All the Questions are compulsory and carry equal marks
1.	Which multiple access technique is used by IEEE 802.11 standard for wireless LAN?
Option A:	ALOHA
Option B:	CDMA
Option C:	MACA
Option D:	TDMA
2.	_____ is a wireless routing protocol.
Option A:	RIP
Option B:	BGP
Option C:	DSDV
Option D:	DSR
3.	One of the step of agent discovery in mobile IP is
Option A:	Agent registration
Option B:	Agent Advertisement
Option C:	Tunneling
Option D:	Binding warning
4.	I-TCP and Snooping TCP does not help much if a mobile host gets
Option A:	Disconnected
Option B:	Out of coverage area
Option C:	Battery power low
Option D:	Mobile hosts are not in same area
5.	VLR and HLR in GSM systems are
Option A:	Gateways for outer connectivity
Option B:	Routers and call management servers
Option C:	Databases of registered users
Option D:	Database for maintaining track of stolen devices
6.	Which of the following component in LTE is acting as a router and forwards data between base station and PDN Gateway?
Option A:	MME
Option B:	ENodeB
Option C:	PGW
Option D:	SGW

7.	The main function of snooping TCP is
Option A:	Flow Control
Option B:	Splits TCP into two connections
Option C:	Congestion Control
Option D:	To buffer data close to the mobile host to perform fast local retransmission in case of packet loss.
8.	A UMTS (Universal Mobile Telecommunication) network is a ___ network.
Option A:	Fourth Generation
Option B:	Second Generation
Option C:	Third Generation
Option D:	First Generation
9.	In case of SON-LTE which of the following is not true?
Option A:	eNodeB configuration is done by itself
Option B:	Manual configuration is needed
Option C:	It is self-organizing
Option D:	It is like Plug and Play
10.	_____ is a procedure the network uses to find out a subscriber's location before actual call establishment.
Option A:	Handover
Option B:	Spread spectrum
Option C:	paging
Option D:	Channel selection
11.	Which of the following is not a component of high level network architecture of LTE?
Option A:	UTRAN
Option B:	EPC
Option C:	MSC
Option D:	UE
12.	Each TDM channel occupies the _____ carrier for 577 μ s in every 4.615ms.
Option A:	400 KHz.
Option B:	200 MHz.
Option C:	200 KHz.
Option D:	800 KHz.
13.	Which of the following spread spectrum techniques were used in the original IEEE 802.11 standard?
Option A:	THSS and DSSS
Option B:	THSS and FHSS
Option C:	CDMA and TDMA
Option D:	FHSS and DSSS
14.	Which of the following technology does not use MIMO?
Option A:	WIMAX
Option B:	4G

Option C:	AMPS
Option D:	5G
15.	In MTC , security checks are executed between _____
Option A:	MT and BTS
Option B:	BSC and MSC
Option C:	MSC and GMSC
Option D:	VLR and MSC
16.	If Mobile Node is in foreign network, to whom it will give a registration request?
Option A:	Foreign Agent (FA)
Option B:	Home Agent (HA)
Option C:	BSC
Option D:	Correspondent Node
17.	_____ in GPRS is used for mobility management.
Option A:	GGSN
Option B:	SGSN
Option C:	PCU
Option D:	BSS
18.	In case of HetNet which of the following is not true?
Option A:	Cells are of same type
Option B:	It uses mix radio technology
Option C:	WiFi working is seamless
Option D:	Cells are of different type
19.	Uplink frequency range in GSM network is
Option A:	935-960 MHZ
Option B:	890-915 MHZ
Option C:	800-950 MHZ
Option D:	810-915 MHZ
20.	Permanent subscriber information is maintained in _____
Option A:	HLR
Option B:	VLR
Option C:	EIR
Option D:	AUC

Q2 (20 Marks)	Solve any Four out of Six	5 marks each
A	Explain how to calculate nearest co- channel cell in cellular system.	
B	List out some advantages of Mobile Computing.	
C	Why the traditional IP cannot be used in a mobile network. What are the main differences between the traditional IP and the mobile IP?	
D	Difference between LTE and LTE-Advanced.	
E	What are the functions of MSC in GSM architecture?	
F	Why is physical layer in IEEE802.11 subdivided ? What are its sublayers?	

Q3. (20 Marks)	Solve any Two Questions out of Three	10 marks each
A	Discuss the architecture of UMTS?	
B	What is triangular routing problem? How do you solve it?	
C	What is the need of Cellular IP? Explain Cellular architecture with paging.	

University of Mumbai
Examination 2021 under cluster 6 (Lead College:VCET)
Examinations Commencing from 15th June 2021

Program: ALL

Curriculum Scheme: Rev2016

Examination: BE Semester VII

Course Code: ILO7013 and Course Name: Management Information Systems

Time: 2 hour

Max. Marks: 80

Question Number	Correct Option (Enter either 'A' or 'B' or 'C' or 'D')
Q1.	C
Q2.	D
Q3.	A
Q4	D
Q5	B
Q6	C
Q7	A
Q8.	A
Q9.	D
Q10.	A
Q11.	A
Q12.	B
Q13.	B
Q14.	D
Q15.	C
Q16.	A
Q17.	C
Q18.	D
Q19.	C
Q20.	A

University of Mumbai
Examination 2021 under cluster 6 (Lead College: VCET)

Examinations Commencing from 15th June 2021

Program: **ALL**

Curriculum Scheme: Rev2016

Examination: BE Semester VII

Course Code: ILO7013 and Course Name: Management Information System

Time: 2 hour

Max. Marks: 80

Q1.	Choose the correct option for following questions. All the Questions are compulsory and carry equal marks
1.	Vital roles that the information systems does not perform for a business enterprise includes _____
Option A:	Support of business processes and applications
Option B:	Support of decision making by employees and managers
Option C:	Support for paper based accounting ledger
Option D:	Support of strategies for competitive advantage
2.	Possible response of the ethical challenges faced by Business managers to implement applications of Information Technology includes_____
Option A:	Implementation of information system solutions
Option B:	Infringement on piracy
Option C:	Inaccurate information
Option D:	Incentives
3.	External forces that affected by element of knowledge management includes _____
Option A:	Globalization of business
Option B:	Technology capability
Option C:	Effectiveness of human resource
Option D:	Disseminating knowledge
4.	Types of data warehouse does not include ____
Option A:	Enterprise data warehouse
Option B:	Data marts

Option C:	Data acquisition centre
Option D:	Operational data warehouse
5.	Identify the correct setup in a database environment
Option A:	User, database, DBMS
Option B:	User, DBMS, database
Option C:	Database, user, DBMS
Option D:	DBMS, database, user
6.	Metadata is the data that describes_____
Option A:	The collection and management of data
Option B:	The subset of the data warehouse
Option C:	The data in the warehouse
Option D:	Operations and shares among users
7.	The reverse auction is normally used in _____marketplace model
Option A:	Buy-side
Option B:	Sell-side
Option C:	Group purchasing
Option D:	Electronic exchange
8.	_____ is the intangible property created by individuals or corporations.
Option A:	Intellectual property
Option B:	Copyright
Option C:	Patent
Option D:	Trade secret

9.	Which is not a Fundamental Tenets of Ethics
Option A:	Responsibility
Option B:	Accountability
Option C:	Liability
Option D:	Digital dossiers
10.	Exposure is ____
Option A:	The harm, loss or damage that can result if a threat compromises an information resource
Option B:	Any danger to which a system/information resource may be exposed
Option C:	The procedures, devices, or software aimed at preventing a compromise to a system.
Option D:	The possibility that the system/information resource will suffer harm by a threat.
11.	Organization XYZ tries to attract customers by providing them with experiences tailored to them. What is this technique referred to?
Option A:	Inbound Marketing
Option B:	Outbound Marketing
Option C:	Search Engine
Option D:	Conversation
12.	_____ act as online intermediaries that harness the power of social networks for introducing, buying, and selling products and services.
Option A:	Group shopping sites
Option B:	Social marketplaces

Option C:	Shopping Communities
Option D:	Peer-to-peer shopping models
13.	Banner advertising _____.
Option A:	Is sent directly to potential customers via e-mail
Option B:	Forces customers to click on an ad to get more information.
Option C:	Is of limited value because it cannot be customized to the target audience.
Option D:	Is another name for pop-up advertising.
14.	All the following describe a VPN except:
Option A:	A VPN uses the Internet as its main backbone network.
Option B:	A VPN relies on network firewalls, encryption, and other Internet and intranet security features.
Option C:	A VPN uses the Internet to establish secure intranets between its distant offices and locations.
Option D:	A VPN is available for use by anyone with access to the Internet.
15.	Older, traditional mainframe-based business information systems are called _____ systems.
Option A:	Historical
Option B:	Standard
Option C:	Legacy
Option D:	Application
16.	A communications medium that consists of one or more central wires surrounded by thick insulation is called _____ cable.
Option A:	Coaxial
Option B:	Fiber optic
Option C:	Twisted-pair
Option D:	Packet-transmission

17.	Data that have been processed by the organization's _____ are inputs into the organization's database.
Option A:	Office automation systems
Option B:	Functional area information systems
Option C:	Transaction processing systems
Option D:	Decision support systems
18.	Which of the following are disadvantages of the buy option for acquiring IS applications?
Option A:	The software exactly meet the company's needs.
Option B:	The software is easy to modify.
Option C:	The companies have control over software improvements.
Option D:	The software may not integrate with existing systems.
19.	Which of the following statements is false?
Option A:	Companies that use Software-as-a-Service are running applications on the vendor's hardware.
Option B:	Application service providers are similar to Software-as-a-Service providers.
Option C:	Companies that purchase open-source software cannot modify it.
Option D:	Outsourcing refers to acquiring IT applications from outside contractors.
20.	Place the stages of the systems development life cycle in order:
Option A:	Investigation – analysis – design – programming/testing – implementation – operation/maintenance
Option B:	Investigation – design – analysis – programming/testing – implementation – operation/maintenance
Option C:	Analysis – design – investigation – operation/maintenance – programming/testing – implementation
Option D:	Investigation – analysis – design – programming/testing – operation/maintenance – implementation

Q2 (20 Marks)	Solve any Four out of Six 5 marks each
A	Explain the elements and objectives of Information Systems with a neat diagram
B	Explain the role of information system in framing organizational strategy and bringing competitive advantage
C	Differentiate between knowledge and information and explain the significance of knowledge for a business firm
D	Define and explain the various types of data warehouse
E	Identify the five factors that contribute to the increasing vulnerability of information resources, and provide a specific example of each one?
F	Compare and contrast human mistakes and social engineering, and provide a specific example of each one?

Q3 (20 Marks)	Solve any Four out of Six 5 marks each
A	Briefly describe the benefits of social commerce to customers.
B	Discuss why social computing is so important in customer relationship management?
C	Differentiate computer network wired and wireless technology?
D	Describe how cloud computing can help organizations expand the scope of their business operations.
E	Explain various ERP implementation strategies
F	Describe the tools that augment the traditional SDLC.

University of Mumbai
Examination 2021 under cluster ALL (Lead College: VCET)

Examinations Commencing from 15th June 2021

Program: **ALL**

Curriculum Scheme: R2016

Examination: BE Semester VII

Course Code: ILO7015 and Course Name: Operations Research

Time: 2 hour

Max. Marks: 80

Question Number	Correct Option (Enter either 'A' or 'B' or 'C' or 'D')
Q1.	B
Q2.	B
Q3.	D
Q4	A
Q5	B
Q6	B
Q7	D
Q8.	A
Q9.	C
Q10.	B
Q11.	B
Q12.	D
Q13.	B
Q14.	D
Q15.	C
Q16.	B
Q17.	B
Q18.	A
Q19.	B
Q20.	A

University of Mumbai

Examination 2021 under cluster ALL (Lead College: VCET)

Examinations Commencing from 15th June 2021

Program: ALL

Curriculum Scheme: R2016

Examination: BE Semester VII

Course Code: ILO7015 and Course Name: Operations Research

Time: 2 hour

Max. Marks: 80

Q1.	Choose the correct option for following questions. All the Questions are compulsory and carry equal marks
1.	Which of the following assumptions of Linear Programming is not obeyed in Integer Linear Programming?
Option A:	Linearity
Option B:	Continuity
Option C:	Additivity
Option D:	Finiteness
2.	Consider the LP problem Maximise $Z = x_1 - 3x_2 + 3x_3$ Subject to, $3x_1 - x_2 + 2x_3 \leq 7$ $2x_1 + 4x_2 \geq -12$ $-4x_1 + 3x_2 + 8x_3 \leq 10$ Where $x_1, x_2, x_3 \geq 0$ In the simplex algorithm, the variables that enters first is ____ and this variable replaces variable ____
Option A:	x_1, s_1
Option B:	x_2, s_3
Option C:	x_3, s_2
Option D:	x_1, s_2
3.	Which statement holds true for the given LP problem : Maximise $Z = 3x_1 + 5x_2$ Subject to, $2x_1 + x_2 \geq 7$ $x_1 + x_2 \geq 6$ $x_1 + 3x_2 \geq 9$ Where $x_1, x_2 \geq 0$
Option A:	This LP has no solution
Option B:	This LP has redundant constraints
Option C:	This LP has multiple solutions.
Option D:	This LP has an unbounded solution
4.	If two jobs J1 and J2 have same minimum process time under first machine but processing time of J1 is less than that of J2 under second machine, then J1 occupies:
Option A:	Second available place from left

Option B:	First available place from the left
Option C:	First available place from right
Option D:	Second available place from right
5.	To solve degeneracy in the transportation problem we have to:
Option A:	Allocate the smallest element epsilon in such a cell, which will form a closed loop with other loaded cells.
Option B:	Allocate the smallest element epsilon in such a cell, which will not form a closed loop with other loaded cells.
Option C:	Put allocation in one of the empty cell as zero
Option D:	Put a small element epsilon in any one of the empty cell
6.	Consider the following six jobs J1,J2,J3,J4,J5,J6 to be processed on two machines A and B in the order A,B . The processing times on machine A are [1,3,8,5,6,3] and on machine B are [5,6,3,2,2,10]. The optimal sequence is :
Option A:	J1-J2-J3-J4-J5-J6
Option B:	J1-J2-J6-J3-J5-J4
Option C:	J1-J2-J4-J5-J6-J4
Option D:	J1-J2-J3-J6-J5-J4
7.	How many routes are possible if travelling salesman travels six cities?
Option A:	10
Option B:	5
Option C:	24
Option D:	120
8.	In a departmental store, one cashier is there to serve the customers and the customers pick up their needs by themselves. The arrival rate is 7 customers for every 5 minutes and the cashier can serve 10 customers in 5 minutes. Assuming Poisson arrival rate and exponential distribution for service rate, the average number of customers in the system are---
Option A:	1.4
Option B:	0.5
Option C:	0.714
Option D:	2
9.	The characteristics of a queuing model is independent of:
Option A:	Service Pattern
Option B:	Number of service stations
Option C:	Queue discipline
Option D:	Limit of length of queue
10.	For a simple queue (M / M / 1), Probability that a person arriving will have to wait is known as ---
Option A:	Random factor
Option B:	Traffic intensity
Option C:	Poisson busy period
Option D:	Exponential service factor
11.	If the outcome at any decision stage is unique and known for the problem, then

	the Dynamic programming problem is known as:
Option A:	Static dynamic programming problem
Option B:	Deterministic dynamic programming problem
Option C:	Probabilistic dynamic programming problem
Option D:	Stochastic dynamic programming problem
12.	In Dynamic Programming Problems, the decisions are made in
Option A:	Single stage
Option B:	No decision making process
Option C:	2-stages
Option D:	Multi-stages
13.	If there are 'n' stages, and recursive equations for each stage is $f_1, f_2 \dots f_n$ and if they are solved in the order f_1 to f_n and optimal return for f_1 is r_1 and that of f_2 is r_2 and so on, then the method of calculation is known as –
Option A:	Direct Computational Procedure
Option B:	Forward computational procedure
Option C:	Reverse Computational Procedure
Option D:	Backward Computational Procedure
14.	Dynamic Programming is also called as :
Option A:	Multistage problem
Option B:	Structural programming
Option C:	State problems
Option D:	Recursive optimization
15.	The value of the following game G is— $\begin{bmatrix} 1 & 13 & 11 \\ -9 & 5 & -11 \\ 0 & -3 & 13 \end{bmatrix}$
Option A:	0
Option B:	-1
Option C:	+1
Option D:	+11
16.	One of the assumption in the game theory is—
Option A:	Winner alone acts rationally
Option B:	All players act rationally and intelligently
Option C:	Loser acts intelligently
Option D:	Both the players believe luck
17.	Which statement holds true for the given game:

	<p style="text-align: center;">Player B</p> <table style="margin-left: auto; margin-right: auto;"> <tr> <td style="padding-right: 10px;">Player A</td> <td style="font-size: 2em; vertical-align: middle;">[</td> <td style="padding: 0 10px;"></td> <td style="font-size: 2em; vertical-align: middle;">]</td> </tr> <tr> <td style="padding-right: 10px;">X</td> <td style="padding: 0 10px;"></td> <td style="text-align: center;">-3</td> <td style="text-align: center;">3</td> </tr> <tr> <td style="padding-right: 10px;">Y</td> <td style="padding: 0 10px;"></td> <td style="text-align: center;">-2</td> <td style="text-align: center;">4</td> </tr> <tr> <td style="padding-right: 10px;">Z</td> <td style="padding: 0 10px;"></td> <td style="text-align: center;">2</td> <td style="text-align: center;">3</td> </tr> </table>	Player A	[]	X		-3	3	Y		-2	4	Z		2	3
Player A	[]														
X		-3	3														
Y		-2	4														
Z		2	3														
Option A:	Game is fair																
Option B:	Game is strictly Determinable																
Option C:	Saddle point is (1,3)																
Option D:	No saddle point exists																
18.	Setup costs do not include :																
Option A:	Cost of processing the work piece																
Option B:	Ordering cost of raw material																
Option C:	Maintenance cost of the machines																
Option D:	Labour cost of setting up machines																
19.	The demand for a commodity is 100 units per day. Every time an order is placed, a fixed cost of Rs. 300 is incurred. Holding cost is Rs. 0.06/- per unit per day. If the lead time is 13 days, then economic lot size is:																
Option A:	300																
Option B:	1000																
Option C:	1200																
Option D:	100																
20.	A particular item has demand of 3000 units per year. The cost of one procurement is Rs. 100 and the holding cost per unit is Rs. 2.40 per year. The replacement is instantaneous and no shortages are allowed. What will be the total cost in per year if the cost of one unit is Rs. 1?																
Option A:	4200																
Option B:	3500																
Option C:	3120																
Option D:	3849																

Q2	Solve any four	5 marks each
A.	A branch of Canara Bank has only one typist. Since the typing work varies in length (number of pages to be typed), the typing rate is randomly distributed approximating a Poisson distribution with mean service rate of 8 letters per hour. The letters arrive at a rate of 5 per hour during the entire 8-hour work day. If the typewriter is valued at Rs. 1.50 per hour, determine—Equipment utilization, average cost due to waiting on the part of typewriter i.e it remaining idle.	
B.	A company manufactures around 200 mopeds. Depending upon the availability of	

raw materials and other conditions, the daily production has been varying from 196 to 204 mopeds, whose probability distribution is as given below:

Production/day	196	197	198	199	200	201	202	203	204
Probability	0.05	0.09	0.12	0.14	0.20	0.15	0.11	0.08	0.06

The finished mopeds are transported in a specifically designed three-storeyed lorry that can accommodate only 200 mopeds. Using the following 15 random numbers 82,89,78,24,53,61,18,45,04,23,50,77,27,54 and 10, simulate the process to find out what will be the average number of mopeds waiting in the factory?

C. A firm has divided its marketing area into three zones. The amount of sales depends upon the number of salesman in each zone. The firm has been collecting the data regarding sales and salesman in each area over a number of past years. The information is given as below.

No. of Salesman	Zone 1	Zone 2	Zone 3
0	30	35	42
1	45	45	54
2	60	52	60
3	70	64	70
4	79	72	82
5	90	82	95
6	98	93	102
7	105	98	110
8	100	100	110
9	90	100	110

For the next year firm has only 9 salesman and the problem is to allocate these salesman to three different zones so that the total sales are maximum.

D. An aircraft company uses rivets at an approximate customer rate of 2,500kg per year. Each unit costs Rs. 30 per kg and the company personnel estimate that it costs Rs. 130 to place an order, and that the carrying cost of inventory is 10 percent per year. How frequently should orders for rivets be placed? Also, determine the optimum size of each order.

E. A and B play a game in which each has three coins a 5p, a 10p and a 20p. Each player selects a coin without the knowledge of the other's choice. If the sum of the coins is an odd amount, A wins B's coin; if the sum is even, B wins A's coin. Find the best strategy for each player and the value of the game.

F. Write the dual of the LPP:

	<p>Maximise $Z = 30x_1 + 23x_2 + 20x_3$</p> <p>Subject to,</p> $6x_1 + 5x_2 + 3x_3 \leq 26$ $4x_1 + 2x_2 + 5x_3 \leq 7$ <p>Where $x_1, x_2, x_3 \geq 0$</p>
--	---

Q3	Solve any Two	10 marks each
-----------	----------------------	----------------------

A.	<p>Solve the following LPP:</p> <p>Maximise $Z = 4x_1 + x_2 + 3x_3 + 5x_4$</p> <p>Subject to,</p> $4x_1 - 6x_2 - 5x_3 - 4x_4 \geq -20$ $-3x_1 - 2x_2 + 4x_3 + x_4 \leq 10$ $-8x_1 - 3x_2 + 3x_3 + 2x_4 \leq 20$ <p>Where $x_1, x_2, x_3, x_4 \geq 0$</p>
----	--

B.	<p>Four jobs 1, 2, 3 and 4 are to be processed on each of the five machines A, B, C, D and E in the order ABCDE. Find the total minimum elapsed time if no passing of jobs is permitted and determine idle time for each machine.</p> <table border="1" style="margin-left: auto; margin-right: auto;"> <thead> <tr> <th>Job</th> <th>Machine A</th> <th>Machine B</th> <th>Machine C</th> <th>Machine D</th> <th>Machine E</th> </tr> </thead> <tbody> <tr> <td>1</td> <td>7</td> <td>5</td> <td>2</td> <td>3</td> <td>9</td> </tr> <tr> <td>2</td> <td>6</td> <td>6</td> <td>4</td> <td>5</td> <td>10</td> </tr> <tr> <td>3</td> <td>5</td> <td>4</td> <td>5</td> <td>6</td> <td>8</td> </tr> <tr> <td>4</td> <td>8</td> <td>3</td> <td>3</td> <td>2</td> <td>6</td> </tr> </tbody> </table>	Job	Machine A	Machine B	Machine C	Machine D	Machine E	1	7	5	2	3	9	2	6	6	4	5	10	3	5	4	5	6	8	4	8	3	3	2	6
Job	Machine A	Machine B	Machine C	Machine D	Machine E																										
1	7	5	2	3	9																										
2	6	6	4	5	10																										
3	5	4	5	6	8																										
4	8	3	3	2	6																										

C	<p>Find initial basic feasible solution by VAM and optimal solution by MODI method:</p>
---	---

	Warehouse A	Warehouse B	Warehouse C	Availability
Factory F1	8	7	3	60
Factory F2	3	8	9	70
Factory F3	11	3	5	80
Demand	50	80	80	

University of Mumbai
Examination 2021 under cluster ALL (Lead College: VCET)

Examinations Commencing from 15th June 2021

Program: ALL_Institute Level Optional Course 1

Curriculum Scheme: Rev2016

Examination: BE Semester VII

Course Code: ILO 7012 and Course Name: Reliability Engineering

Time: 2 hour

Max. Marks: 80

Question Number	Correct Option (Enter either 'A' or 'B' or 'C' or 'D')
Q1.	A
Q2.	C
Q3.	B
Q4	A
Q5	B
Q6	C
Q7	B
Q8.	C
Q9.	A
Q10.	C
Q11.	D
Q12.	C
Q13.	D
Q14.	D
Q15.	C
Q16.	A
Q17.	A
Q18.	B
Q19.	D
Q20.	B